

JVC

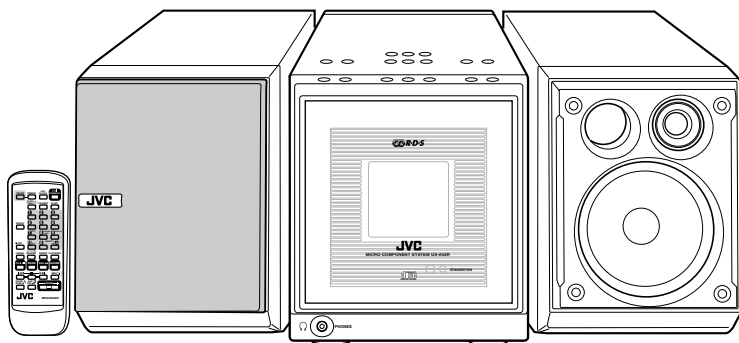

MICRO COMPONENT SYSTEM

UX-A52R — Consists of CA-UXA52R and SP-UXA52



COMPACT
disc
DIGITAL AUDIO

INSTRUCTIONS

For Customer Use:

Enter below the Model No. and Serial No. which are located either on the rear, bottom or side of the cabinet. Retain this information for future reference.

Model No. _____

Serial No. _____

GVT0071-008A

[B]

Warnings, Cautions and Others

IMPORTANT for the U.K.

DO NOT cut off the mains plug from this equipment. If the plug fitted is not suitable for the power points in your home or the cable is too short to reach a power point, then obtain an appropriate safety approved extension lead or consult your dealer.

BE SURE to replace the fuse only with an identical approved type, as originally fitted.

If nonetheless the mains plug is cut off ensure to remove the fuse and dispose of the plug immediately, to avoid a possible shock hazard by inadvertent connection to the mains supply.

If this product is not supplied fitted with a mains plug then follow the instructions given below:

IMPORTANT:

DO NOT make any connection to the terminal which is marked with the letter E or by the safety earth symbol or coloured green or green-and-yellow.

The wires in the mains lead on this product are coloured in accordance with the following code:

Blue : Neutral
Brown : Live

As these colours may not correspond with the coloured markings identifying the terminals in your plug proceed as follows:

The wire which is coloured blue must be connected to the terminal which is marked with the letter N or coloured black.

The wire which is coloured brown must be connected to the terminal which is marked with the letter L or coloured red.

IF IN DOUBT - CONSULT A COMPETENT ELECTRICIAN.

Caution — STANDBY/ON button!

Disconnect the mains plug to shut the power off completely (the STANDBY/ON lamp goes off).

The  STANDBY/ON button in any position does not disconnect the mains line.

- When the unit is on standby, the STANDBY/ON lamp lights red.
- When the unit is turned on, the STANDBY/ON lamp lights green.

The power can be remote controlled.

CAUTION

To reduce the risk of electrical shocks, fire, etc.:

1. Do not remove screws, covers or cabinet.
2. Do not expose this appliance to rain or moisture.

CAUTION

- Do not block the ventilation openings or holes.
(If the ventilation openings or holes are blocked by a newspaper or cloth, etc., the heat may not be able to get out.)
- Do not place any naked flame sources, such as lighted candles, on the apparatus.
- When discarding batteries, environmental problems must be considered and local rules or laws governing the disposal of these batteries must be followed strictly.
- Do not expose this apparatus to rain, moisture, dripping or splashing and that no objects filled with liquids, such as vases, shall be placed on the apparatus.

Caution: Proper Ventilation

To avoid risk of electric shock and fire, and to prevent damage, locate the apparatus as follows:

1 Front:

No obstructions and open spacing.

2 Sides/ Top/ Back:

No obstructions should be placed in the areas shown by the dimensions below.

3 Bottom:

Place on the level surface. Maintain an adequate air path for ventilation by placing on a stand with a height of 10 cm or more.

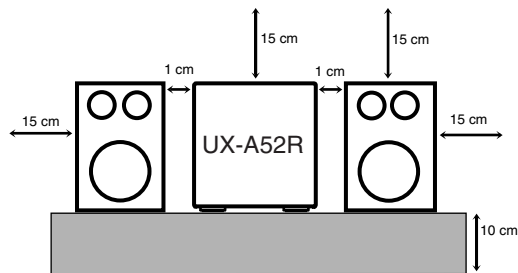
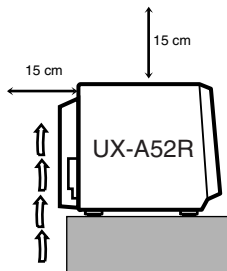
Front view**Side view**

IMPORTANT FOR LASER PRODUCTS

REPRODUCTION OF LABELS

- ① CLASSIFICATION LABEL, PLACED ON EXTERIOR SURFACE

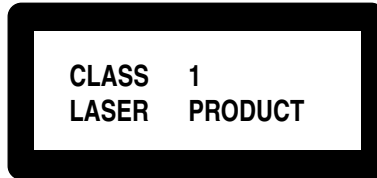

1. CLASS 1 LASER PRODUCT
2. **DANGER:** Invisible laser radiation when open and interlock failed or defeated. Avoid direct exposure to beam.
3. **CAUTION:** Do not open the top cover. There are no user serviceable parts inside the Unit; leave all servicing to qualified service personnel.

- ② WARNING LABEL, PLACED INSIDE THE UNIT

DANGER: Invisible laser radiation when open and interlock failed or defeated. AVOID DIRECT EXPOSURE TO BEAM. (e)	VARNING: Osynlig laserstrålning när denna del är öppnad och spärren är urkopplad. Betrakta ej strålen. (s)
ADVARSEL: Usynlig laserstrålning ved åbning, når sikkerhedsafbrydere er ude af funktion. Undgåudsætelse for stråling. (d)	VARO: Avattaessa ja suojalukitus ohitettaessa olet alttiina näkymättömälle lasersäteilylle. Älä katso säteeseen. (f)

SAFETY INSTRUCTIONS

“SOME DOS AND DON'TS ON THE SAFE USE OF EQUIPMENT”

This equipment has been designed and manufactured to meet international safety standards but, like any electrical equipment, care must be taken if you are to obtain the best results and safety is to be assured.

Do read the operating instructions before you attempt to use the equipment.

Do ensure that all electrical connections (including the mains plug, extension leads and interconnections between pieces of equipment) are properly made and in accordance with the manufacturer's instructions. Switch off and withdraw the mains plug when making or changing connections.

Do consult your dealer if you are ever in doubt about the installation, operation or safety of your equipment.

Do be careful with glass panels or doors on equipment.

DON'T continue to operate the equipment if you are in any doubt about it working normally, or if it is damaged in any way – switch off, withdraw the mains plug and consult your dealer.

DON'T remove any fixed cover as this may expose dangerous voltages.

DON'T leave equipment switched on when it is unattended unless it is specifically stated that it is designed for unattended operation or has a standby mode.

Switch off using the switch on the equipment and make sure that your family know how to do this.

Special arrangements may need to be made for infirm or handicapped people.

DON'T use equipment such as personal stereos or radios so that you are distracted from the requirements of traffic safety. It is illegal to watch television whilst driving.

DON'T listen to headphones at high volume as such use can permanently damage your hearing.

DON'T obstruct the ventilation of the equipment, for example with curtains or soft furnishings.

Overheating will cause damage and shorten the life of the equipment.

DON'T use makeshift stands and NEVER fix legs with wood screws — to ensure complete safety always fit the manufacturer's approved stand or legs with the fixings provided according to the instructions.

DON'T allow electrical equipment to be exposed to rain or moisture.

ABOVE ALL

- NEVER let anyone, especially children, push anything into holes, slots or any other opening in the case
 - this could result in a fatal electrical shock.
- NEVER guess or take chances with electrical equipment of any kind — it is better to be safe than sorry!



Introduction

We would like to thank you for purchasing one of our JVC products. Before operating this unit, read this manual carefully and thoroughly to obtain the best possible performance from your unit, and retain this manual for future reference.

About This Manual

This manual is organized as follows:

- This manual mainly explains playback using the remote control, and the other operations such as recording operations using the buttons on the unit. You can use the buttons both on the remote control and on the unit for the same operations if they have the same or similar names (or marks), unless mentioned otherwise.
- Basic and common information that is the same for many functions is grouped in one place, and is not repeated in each procedure. For instance, we do not repeat the information about turning on/off the unit, setting the volume, changing the sound effects, and others, which are explained in the section “Basic and Common Operations” on pages 10 – 13.
- The following marks are used in this manual:

	Gives you warning and caution to prevent from damage or risk of fire/electric shock. Furthermore, gives you information which is not good for obtaining the best possible performance from the unit.
	Gives you information and hints you had better know.

Precautions

Installation

- Install in a place which is level, dry and neither too hot nor too cold—between 5°C and 35°C.
- Install the unit in a location with adequate ventilation to prevent internal heat buildup in the unit.
- Leave sufficient distance between the unit and the TV.
- Keep the speakers away from the TV to avoid interference with TV.

 DO NOT install the unit in a location near heat sources, or in a place subject to direct sunlight, excessive dust or vibration.

Power sources

- When unplugging the unit from the wall outlet, always pull the plug, not the AC power cord.

 DO NOT handle the AC power cord with wet hands.

Moisture condensation

Moisture may condense on the lens inside the unit in the following cases:

- After starting heating in the room
 - In a damp room
 - If the unit is brought directly from a cold to a warm place
- Should this occur, the unit may malfunction. In this case, leave the unit turned on for a few hours until the moisture evaporates, unplug the AC power cord, then plug it in again.

Others

- Should any metallic object or liquid fall into the unit, unplug the AC power cord and consult your dealer before operating any further.
- If you are not going to operate the unit for an extended period of time, unplug the AC power cord from the wall outlet.

 DO NOT disassemble the unit since there are no user serviceable parts inside.

If anything goes wrong, unplug the AC power cord and consult your dealer.

Contents

Location of the Buttons	3	Playing Back a CD	20
Main Unit	3	Precautions on CD Playback	21
Remote Control	5	Playing Back the Entire CD—Normal Play	21
Getting Started.....	6	Basic CD Operations	22
Unpacking	6	Programming the Playing Order of the Tracks	
Putting the Batteries into the Remote Control	6	—Program Play	23
Connecting Antennas	7	Playing at Random—Random Play	24
Connecting Speakers	8	Repeating Tracks—Repeat Play	24
Connecting Other Equipment	9	Playing Back a Tape	25
Basic and Common Operations.....	10	Playing Back a Tape	26
Turning On the Power	11	Using External Equipment	27
Selecting the Sources and Starting Play	11	Listening to External Equipment	28
Adjusting the Volume	12	Recording from This Unit	
Turning On/Off the Key-touch Tone	12	to External Equipment	28
Reinforcing the Bass Sound	12	Recording on Tapes	29
Selecting the Sound Modes	12	Before You Start Recording	30
Setting the Display Illumination	13	Recording FM/AM (MW/LW) Broadcasts	31
Listening to FM and AM (MW/LW)		Recording CD—CD Synchronized Recording	31
Broadcasts	14	Recording External Equipment	32
Tuning in a Station	15	Using the Timers	33
Presetting Stations	15	Setting the Clock	34
Tuning in a Preset Station	16	Using Recording Timer	34
Receiving FM Stations with RDS	16	Using Daily Timer	35
Changing the RDS Information	16	Using Sleep Timer	37
Searching for Programs by PTY Codes		Timer Priority	37
(PTY search)	16	Maintenance	38
Switching to a Program Type of Your Choice		Troubleshooting	39
Temporarily	17	Specifications	40
• How the Enhanced Other Networks			
function actually works	18		
• Description of the PTY codes	19		

Location of the Buttons

Become familiar with the buttons on your unit.

Main Unit

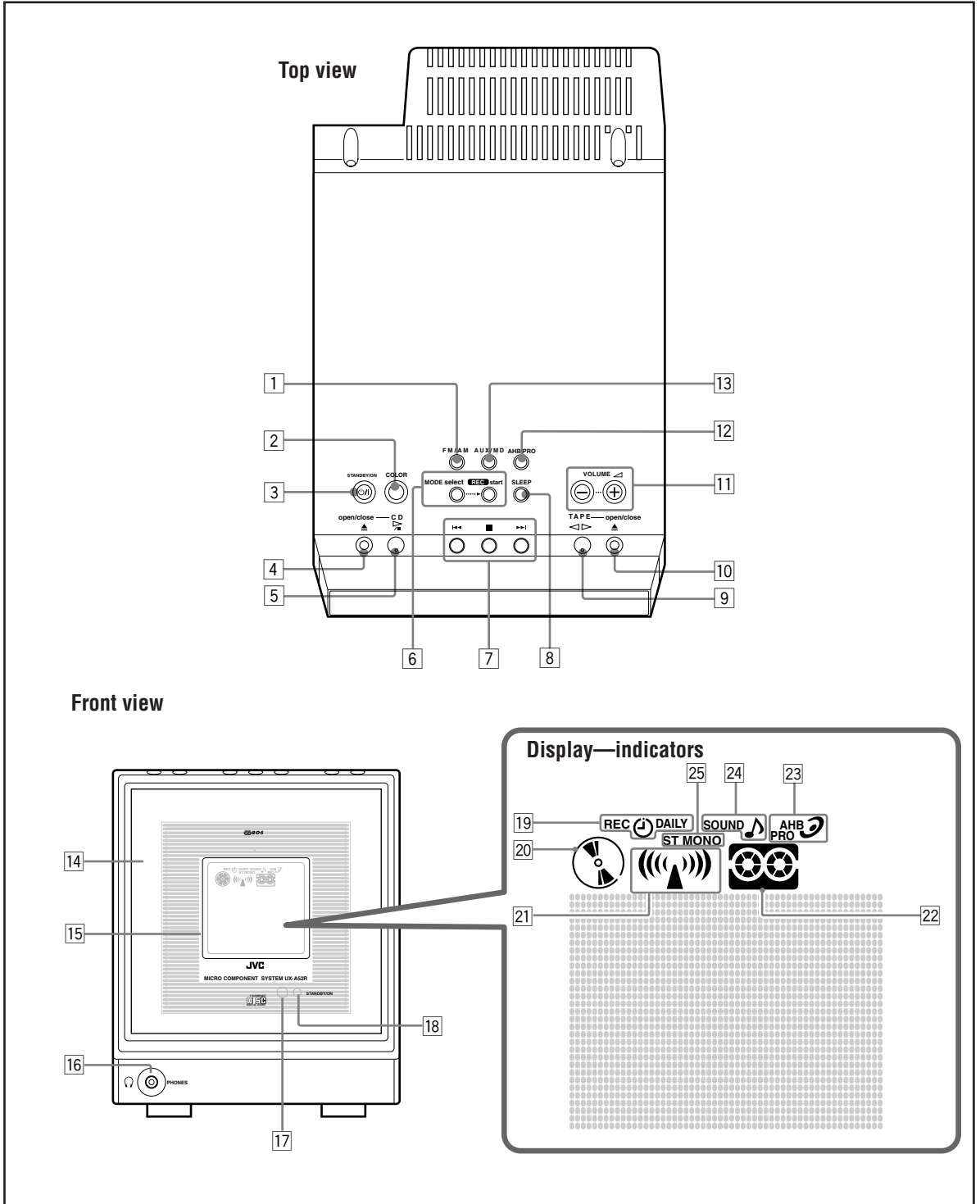

See pages in the parentheses for details.

Main unit

- 1 FM/AM button (11, 15)
 - Pressing this button also turns on the unit.
- 2 COLOR button (9, 13)
- 3 \odot/I STANDBY/ON button (11)
- 4 CD open/close \blacktriangle button (21 – 23)
 - Pressing this button also turns on the unit.
- 5 CD \triangleright/II (play/pause) button (11, 21, 31)
 - Pressing this button also turns on the unit.
- 6 MODE select and REC start buttons (31, 32)
- 7 Multi operation buttons
 - \blacktriangleleft (reverse skip), \blacksquare (stop), and \blacktriangleright (forward skip)
- 8 SLEEP button (37)
- 9 TAPE $\triangleleft/\triangleright$ (play) button (11, 26, 31, 32)
 - Pressing this button also turns on the unit.
- 10 TAPE open/close \blacktriangle button (26)
 - Pressing this button also turns on the unit.
- 11 VOLUME + / – buttons (12, 28)
- 12 AHB (Active Hyper Bass) PRO button (12, 28)
- 13 AUX/MD button (11, 28, 32)
 - Pressing this button also turns on the unit.
- 14 Electronic swing panel
- 15 Display
 - Shows the source name and some indicators, etc.
- 16 PHONES (\odot) jack—stereo mini-type (12)
- 17 Remote sensor
- 18 STANDBY/ON lamp (11)

Display—indicators

- 19 Timer mode indicators (34 – 37)
 - \odot (Timer), DAILY (Daily Timer), and REC (Recording Timer)
- 20 CD indicator
 - Lights when CD is in the disc tray.
- 21 Tuner indicator
 - Lights when the tuner is selected as the source.
- 22 Tape indicator
 - Lights when a cassette is in the cassette loading slot.
- 23 AHB (Active Hyper Bass) PRO indicator (12)
- 24 SOUND indicator (12)
- 25 ST (stereo) and MONO indicators (15)

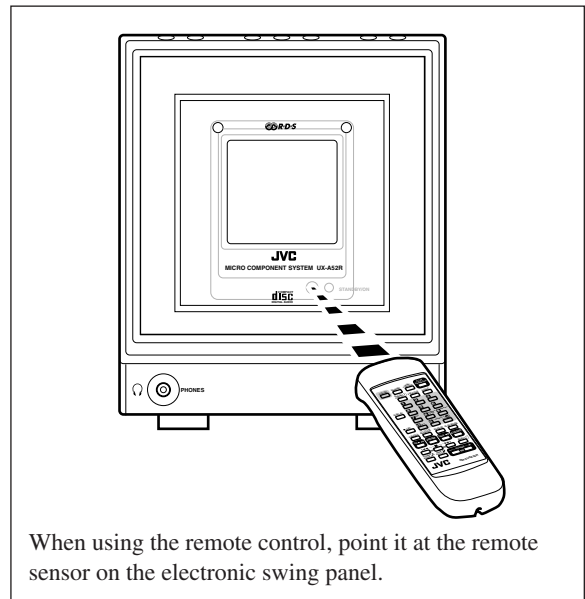

Remote Control

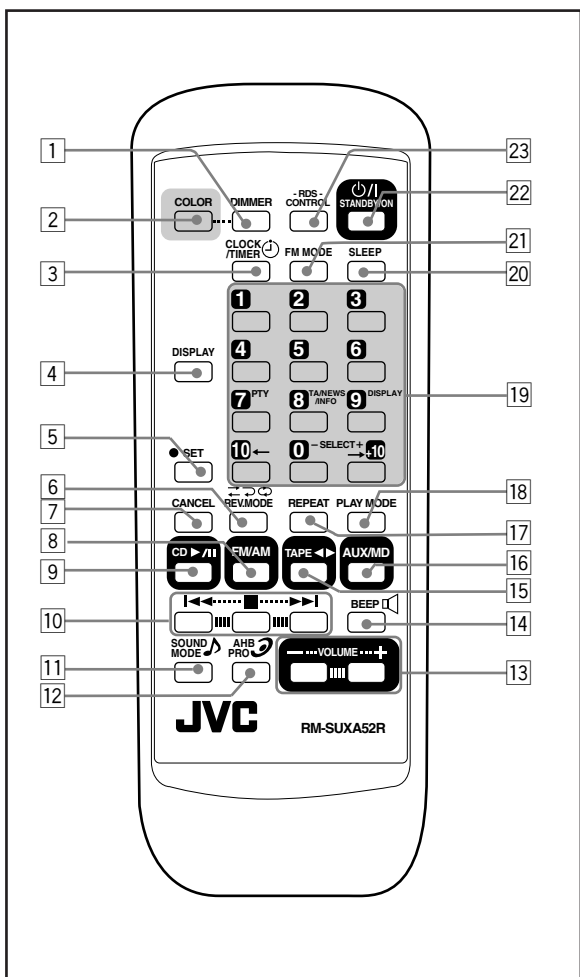

Remote control

- 1 DIMMER button (13, 34)
- 2 COLOR button (9, 13)
- 3 CLOCK/TIMER button (34 – 36)
- 4 DISPLAY button (16, 22, 26, 31, 32)
- 5 SET button (13, 15, 34 – 37)
- 6 REV. (reverse) MODE button (26)
- 7 CANCEL button (23, 34, 35)
- 8 FM/AM button (11, 15, 16)
 - Pressing this button also turns on the unit.
- 9 CD ► / || (play/pause) button (11, 21 – 24)
 - Pressing this button also turns on the unit.
- 10 Multi operation buttons
 - ◀◀ (reverse skip), ■ (stop), and ▶▶ (forward skip)
- 11 SOUND MODE button (12, 28)
- 12 AHB (Active Hyper Bass) PRO button (12, 28)
- 13 VOLUME + / – buttons (12, 28)
- 14 BEEP button (12)
- 15 TAPE ◀ ▶ button (11, 26)
 - Pressing this button also turns on the unit.
- 16 AUX/MD button (11, 28)
 - Pressing this button also turns on the unit.
- 17 REPEAT button (24)
- 18 PLAY MODE button (23, 24)
- 19 Number buttons
 - 0, 1 – 10, +10 buttons
 - RDS operating buttons—PTY, TA/NEWS/INFO, DISPLAY, SELECT + / – (16, 17)
 - ◀ / ▶ buttons (13)
- 20 SLEEP button (37)
- 21 FM MODE button (15)
- 22 ◻/ STANDBY/ON button (11, 35, 36)
- 23 RDS CONTROL button (16, 17)

Unpacking

Make sure that you have all the following items.
The number in parentheses indicates the quantity of the pieces supplied.

- FM antenna (1)
- AM (MW/LW) loop antenna (1)
- AC power cord (1)
- Remote control (1)
- Batteries (2)

If anything is missing, consult your dealer immediately.

Putting the Batteries into the Remote Control

Insert the batteries—R6P(SUM-3)/AA(15F)—into the remote control, by matching the polarity (+ and –) on the batteries with the + and – marking on the battery compartment.

When the remote control can no longer operate the unit, replace both batteries at the same time.

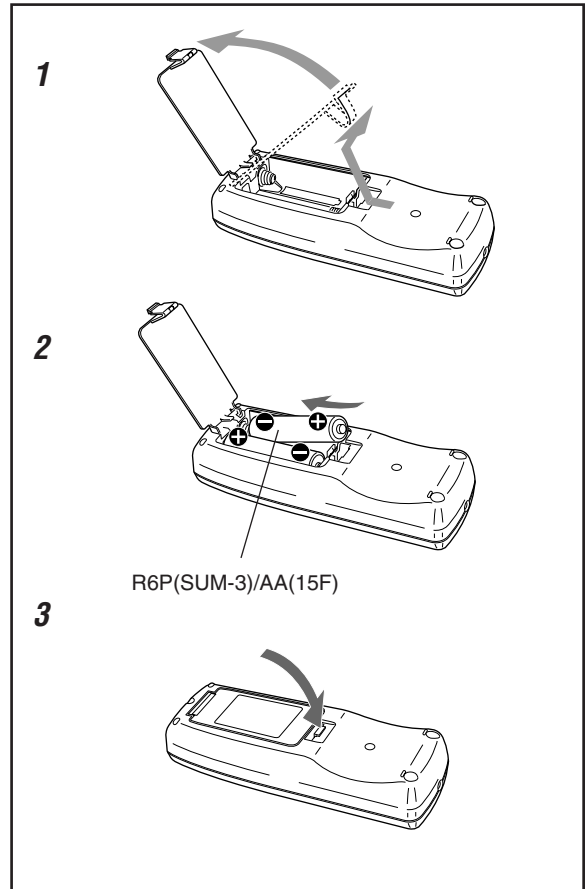

- DO NOT use an old battery together with a new one.
- DO NOT use different types of batteries together.
- DO NOT expose batteries to heat or flame.
- DO NOT leave the batteries in the battery compartment when you are not going to use the remote control for an extended period of time. Otherwise, it will be damaged from battery leakage.

Connecting Antennas

FM antenna

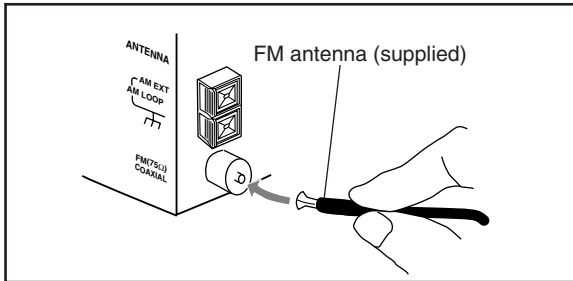

- 1** Attach the FM antenna to the FM (75 Ω) COAXIAL terminal.
- 2** Extend the FM antenna.
- 3** Fasten it up in the position which gives you the best reception.



About the supplied FM antenna

The FM antenna supplied with this unit can be used as temporary measure. If reception is poor, you can connect an outdoor FM antenna.

To connect an outdoor FM antenna

Before connecting it, disconnect the supplied FM antenna.

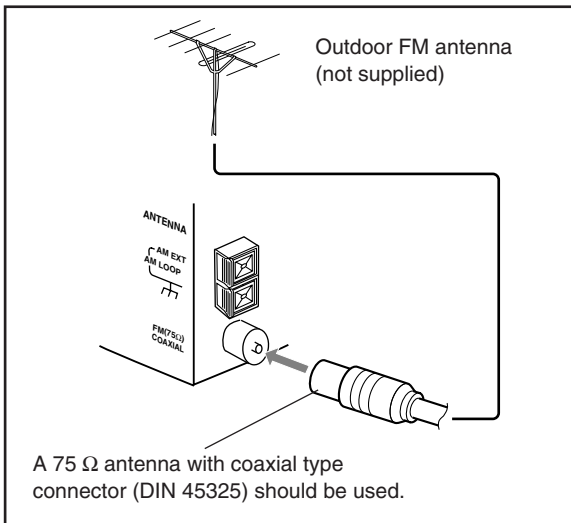

AM (MW/LW) antenna

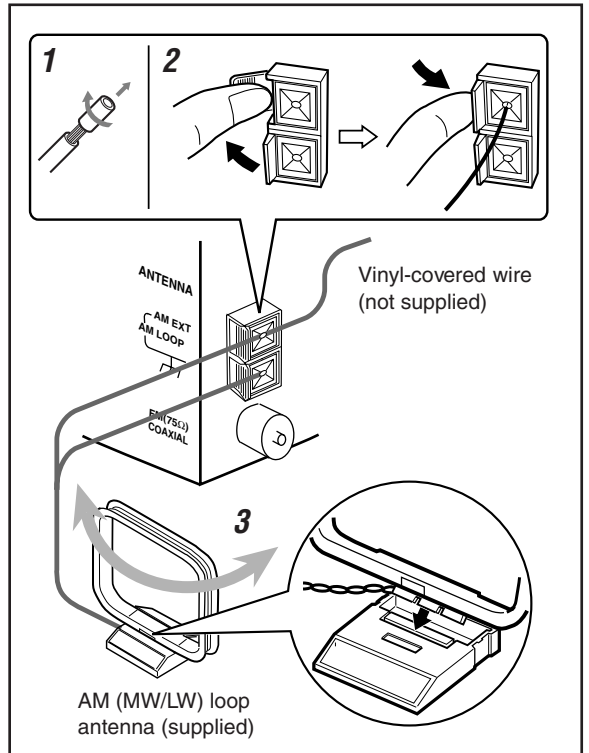

- 1** If cords are covered with insulation, twist the core of the cord at the end of each cord, then remove the insulation.
- 2** Connect the AM (MW/LW) loop antenna to the AM LOOP terminals as illustrated.
- 3** Turn the AM (MW/LW) loop antenna until you have the best reception.

To connect an outdoor AM (MW/LW) antenna

When reception is poor, connect a single vinyl-covered wire to the AM EXT terminal and extend it horizontally. The AM (MW/LW) loop antenna must remain connected.



For better reception of both FM and AM (MW/LW)

- Make sure the antenna conductors do not touch any other terminals and connecting cords.
- Keep the antennas away from metallic parts of the unit, connecting cords, and the AC power cord.

Connecting Speakers

To connect speakers

You can connect the speakers by following the procedure below:

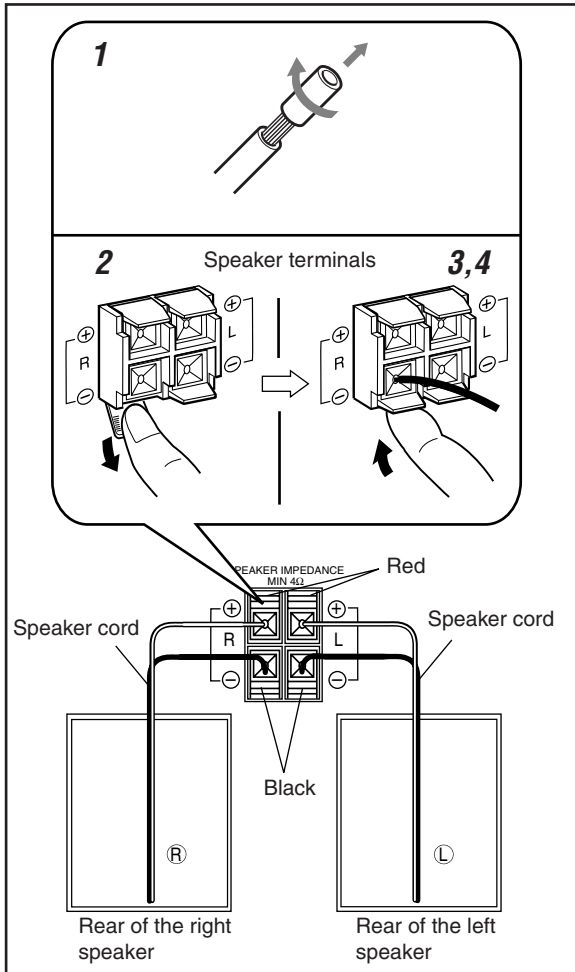

- 1** If cords are covered with insulation, twist the core of the cord at the end of each cord, then remove the insulation.
- 2** Open the speaker terminal.
- 3** Insert the end of the speaker cord to the terminal. Match the polarity: White cord to red (+) terminal and black cord to black (-) terminal.
- 4** Close the speaker terminal on the rear of the unit.

Use only speakers with the speaker impedance—4 Ω to 16 Ω.

To remove the speaker grilles

The speaker grilles are removable.

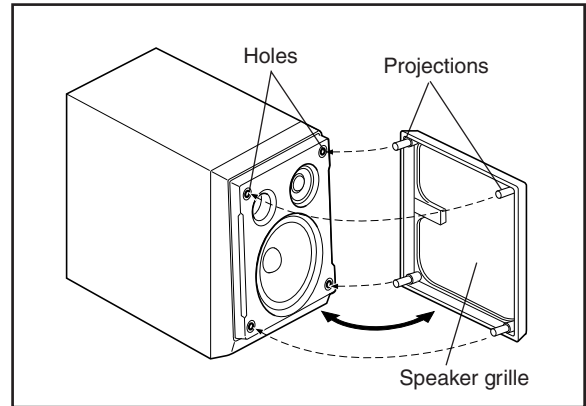

To remove the speaker grille, insert your fingers at the top of the speaker grille, then pull towards you. Do the same at the bottom.

To attach the speaker grille, put the projections of the speaker grille into the holes of the speaker.

Connecting Other Equipment

You can connect both of the analog and digital equipment. When you connect and use the equipment, refer also to its manual supplied.



- DO NOT connect other equipment while the power is on.
- DO NOT plug in any equipment until all connections are complete.

To connect analog audio equipment

Be sure that the plugs of the audio cords and the jacks on the rear of the unit are color-coded: White plugs and jacks are for left audio signals, and red ones for right audio signals.

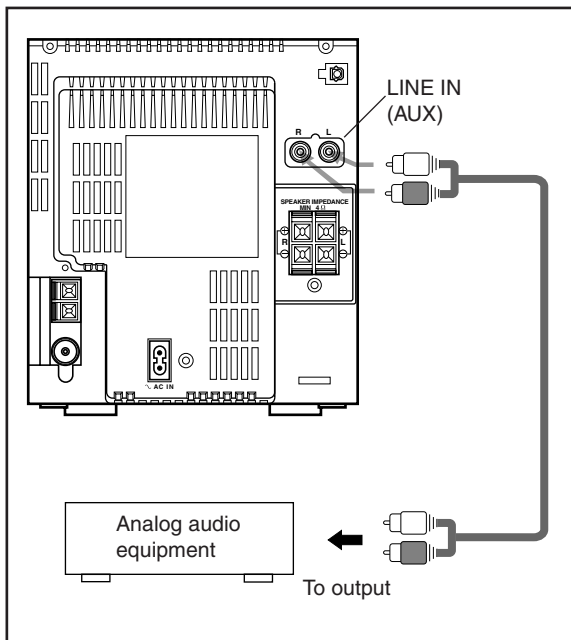

For playing the other equipment through this unit, connect between the audio output jacks on the other equipment and the LINE IN (AUX) jacks by using an audio cord (not supplied.)

To connect audio equipment with an optical digital input terminal

You can record CD sound onto the connected digital equipment.

Connect an optical digital cord (not supplied) between the optical digital input terminal on the other equipment and the OPTICAL DIGITAL OUT terminal.

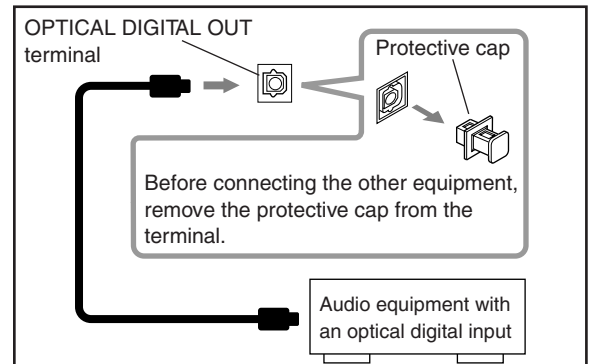

NOW, you can plug the AC power cord.

IMPORTANT: Be sure to check all connections to be done before plugging the AC power cord into a wall outlet.

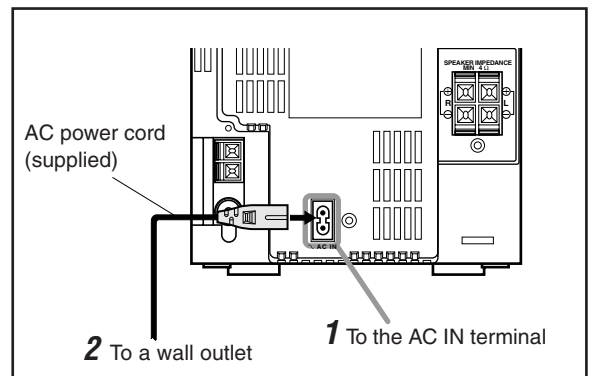

When connecting the AC power cord into a wall outlet, the unit automatically starts the display illumination.

To stop and cancel the display demonstration, press COLOR during display illumination—while the unit is turned off (on standby.)

To start the display illumination manually, press COLOR again while the unit is turned off (on standby.)

Basic and Common Operations

Continued 

The buttons emphasized in the illustration below are used and explained in this section (pages 11 to 13.)

Remote control

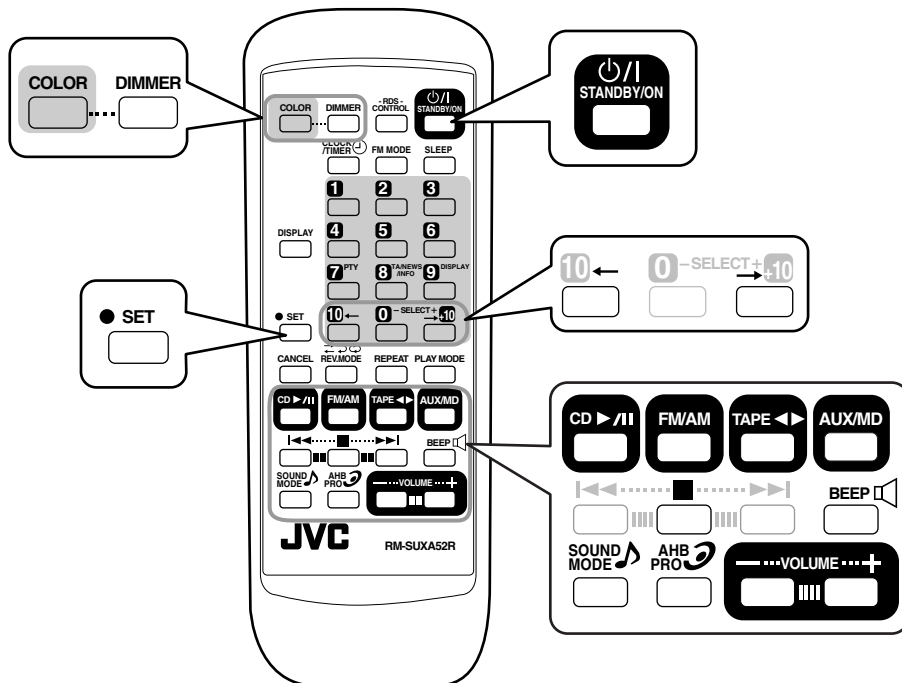

Main unit (Top view)

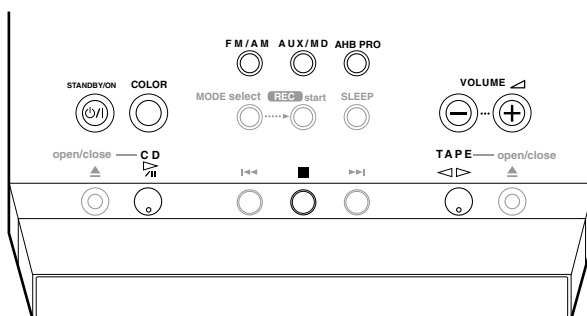

Main unit (Front view)

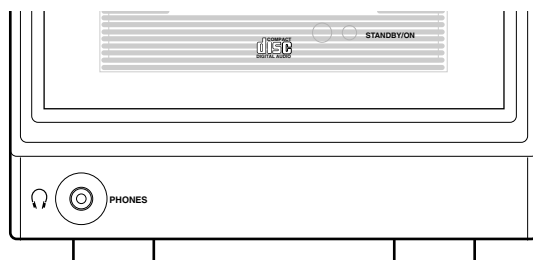

Turning On the Power

When you press the play buttons (CD ► / II, TAPE ◀ ►) for a particular source or FM/AM and AUX/MD, the unit automatically turns on (and starts playback if the source is ready.)

To turn on the unit without playing, press
⓪/II STANDBY/ON.

The STANDBY/ON lamp on the electronic swing panel lights green.

To turn off the unit (on standby), press
⓪/II STANDBY/ON again.

The STANDBY/ON lamp on the electronic swing panel lights red.

- “0:00” appears on the display until you set the built-in clock. After setting the clock, the clock time will appear on the display while the unit is turned off (on standby.)
- A little power is always consumed even while the unit is on standby.

To set the built-in clock, see page 34.

To switch off the power supply completely, unplug the AC power cord from the AC outlet.



When you unplug the AC power cord or if a power failure occurs

The clock setting, the tuner preset stations and other settings will be erased.

Selecting the Sources and Starting Play

To select the tuner, press FM/AM.

The unit automatically turns on (when the unit is on standby) and the last selected station is tuned in.

Each time you press FM/AM, the band alternates between FM and AM (MW/LW.)

- For more detailed operations, see pages 14 to 19.

To select the CD player, press CD ► / II.

The unit automatically turns on (when the unit is on standby), and “CD” appears on the display. Play will start if a CD is on the disc tray. (“NO DISC” will appear on the display if a CD is not loaded.)

To stop playback, press ■.

- For more detailed operations, see pages 20 to 24.

To select the cassette deck, press TAPE ◀ ►.

The unit automatically turns on (when the unit is on standby), and “TAPE” appears on the display. Play will start if a cassette is in the cassette loading slot. (“NO TAPE” will appear on the display if a cassette is not in the cassette loading slot.)

To stop playback, press ■.

- For more detailed operations, see pages 25 and 26.

To select external equipment, press AUX/MD.

The unit automatically turns on (when the unit is on standby), and “AUX” appears on the display.

- For more detailed operations, see pages 27 and 28.
- For operating the external equipment, see the manuals supplied with them.

Adjusting the Volume

You can adjust the volume level while the unit is turned on. The volume level has no effect on recording.

To increase the volume, press VOLUME +.

To decrease the volume, press VOLUME –.

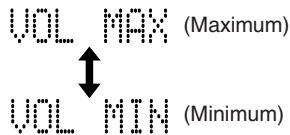

The volume level meter appears on the display.

- The volume level can be adjusted in 41 steps (VOL MIN, VOL 1 – VOL 39, and VOL MAX.)
- When pressing and holding the button, you can change the volume level continuously.



For private listening

Connect the headphones to the PHONES jack. No sound comes out of the speakers. Be sure to turn down the volume before connecting or putting on the headphones.



DO NOT turn off (on standby) the unit with the volume set to an extremely high level; otherwise, the sudden blast of sound can damage your hearing, speakers and/or headphones when you turn on the unit or start playing any source.
REMEMBER you cannot adjust the volume level while the unit is on standby mode.

Turning On/Off the Key-touch Tone

If you do not want the key-touch tone to beep each time you press buttons, you can deactivate it while the unit is turned on.

On the remote control ONLY:

Press BEEP.

- Each time you press the button, the key-touch tone turns on (BEEP ON) and off (BEEP OFF) alternately:

BEEP ON ↔ BEEP OFF

Reinforcing the Bass Sound

The richness and fullness of the bass sound is clearly maintained regardless of how low you set the volume—Active Hyper Bass PRO. You can select the bass effect levels while the unit is turned on. The AHB PRO can be applied only to playback sounds, and cannot be used for recording.

To get the effect, press AHB PRO.

The AHB PRO indicator lights on the display.

- Each time you press the button, the effect changes as follows:

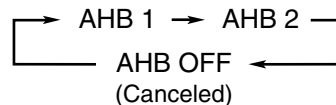

AHB 1: Bass sound is clearly heard even in the low volume.

AHB 2: Bass sound is more effective than AHB 1.

AHB OFF: Cancels the AHB PRO.

The AHB PRO indicator goes off from the display.

To check the AHB PRO setting currently selected, press AHB PRO once while the AHB PRO indicator is lit.

Selecting the Sound Modes

You can select one of the 4 preset sound modes while the unit is turned on. The sound modes can be applied only to playback sounds, and cannot be used for recording.

On the remote control ONLY:

To select the sound modes, press SOUND MODE repeatedly until the sound mode you want appears on the display.

The SOUND indicator also lights on the display.

- Each time you press the button, the sound mode changes as follows:

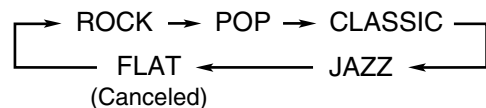

ROCK: Boosts low and high frequency. Good for acoustic music.

POP: Good for vocal music or voice.

CLASSIC: Good for classical music.

JAZZ: Good for jazz music.

FLAT: Cancels the sound mode.

The SOUND indicator goes off from the display.

To check the sound mode currently selected, press SOUND MODE once while the SOUND indicator is lit.

Setting the Display Illumination

You can change the color and brightness of the display illumination.

To select the color pattern

You can select the color pattern by your preference.

While the unit is turned on, press **COLOR** repeatedly until the color pattern you want appears on the display.

- Each time you press the button, the color pattern changes as follows:

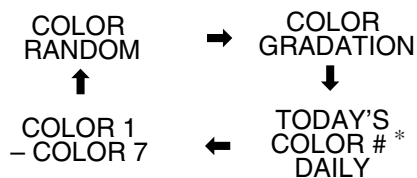

COLOR RANDOM: Changes the illumination color randomly every 2 seconds.

COLOR GRADATION: Changes the illumination color gradually.

TODAY'S COLOR #* DAILY: Changes the illumination color every day. You can select which color to start with. (See "To select TODAY'S COLOR" to the right column.)

- * The color number of TODAY'S COLOR is selected from COLOR 1 – 7.

COLOR 1 – 7: You can adjust and register the color from COLOR 1 to 7. (See "To adjust and register the color" to the right column.)

- If you press **COLOR** while the unit is turned off, the display illumination will start (see page 9.)



More on the display illumination

- The colors shown on the display cannot always be reproduced precisely. Due to the circumstances (room temperature, etc.) where the unit is used, colors may vary slightly.
- When you change the color of the display, the display may seem to move back and forth; this is a characteristic of this unit and is not a malfunction.
- When a strong light strikes the display, the display happens to become dark, but this is not a malfunction.

To adjust and register the color

You can adjust the color by changing the tone, whiteness, brightness, and register into COLOR 1 to 7.

- There is a time limit in doing the following steps. If the setting is canceled before you finish, start from step **1** again.

On the remote control ONLY:

- 1** Press **COLOR** repeatedly until the color number (COLOR 1 to 7) you want to adjust appears on the display.

The adjustment bars appear on the display.



- 2** Adjust the tone, whiteness, and brightness.

- 1) Press → or ← to select the level you want and press SET.**

- Each time you press **SET**, the adjustment items change.
- The tone can be adjusted in 14 patterns. The whiteness can be adjusted in 3 levels and the brightness can be adjusted in 2 levels.

- 2) Repeat 1) to adjust "WHITENESS" and "BRIGHTNESS."**

- If the whiteness is set to the right end, the tone you adjusted will be no longer valid.

To select "TODAY'S COLOR"

The illumination color changes automatically each time the built-in clock becomes "0:00."

- There is a time limit in doing the following steps. If the setting is canceled before you finish, start from step **1** again.

On the remote control ONLY:

- 1** Press **COLOR** repeatedly until "TODAY'S COLOR" appears on the display.

- 2** Press → or ← to select the color number (COLOR 1 to 7.)

To dim the display

This function can be used only while the unit is turned on.

On the remote control ONLY:

To dim the display, press **DIMMER**.

To brighten the display, press **DIMMER** again.

- Pressing **COLOR** also brightens the display.

Listening to FM and AM (MW/LW) Broadcasts

The buttons emphasized in the illustration below are used and explained in this section (pages 15 to 19.)

Remote control

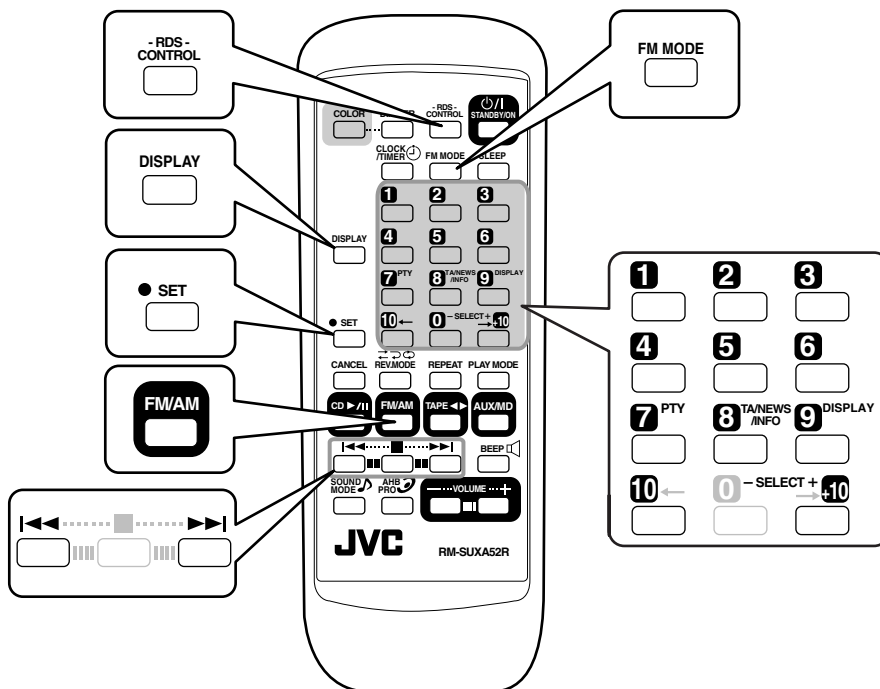

For RDS (Radio Data System) operations, use the green letter buttons on the remote control.

Main unit (Top view)

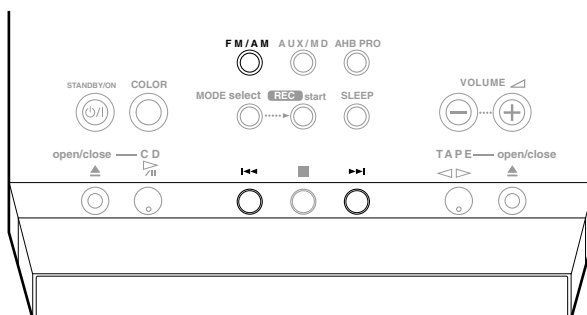

Tuning in a Station

1 Press FM/AM repeatedly to select “FM” or “AM (MW/LW).”

The unit automatically turns on with the last selected station.

- Each time you press the button, the band alternates between FM and AM (MW/LW.)

2 Press and hold ►► or ◄◄ until the station frequencies start changing on the display.

- ►►: to increase the frequencies.
- ◄◄: to decrease the frequencies.

The unit starts searching stations and stops when a station of sufficient signal strength is tuned in.

FM
87.50MHz

Ex. An FM station is tuned in.

- If an FM program is broadcast in stereo, the ST (stereo) indicator lights on the display.

To stop during searching, press ►► or ◄◄.



When you press ►► or ◄◄ repeatedly the frequency changes step by step.

To change the FM reception mode

When an FM stereo broadcast is noisy or hard to receive, you can change the FM reception mode to improve the reception.

On the remote control ONLY:

Press FM MODE so that the MONO indicator lights on the display.

- Each time you press the button, the MONO indicator lights and goes off alternately.

When the MONO indicator is lit:

Reception improves though stereo effect is lost.

When the MONO indicator is not lit:

You can hear stereo sound when a program is broadcast in stereo.

The ST (stereo) indicator lights while receiving the FM stereo broadcast (only when the reception is good.)

In addition, static noise between stations will be erased while tuning.

Presetting Stations

You can preset 30 FM and 15 AM (MW/LW) stations manually.

In some cases, test frequencies have been already memorized for the tuner since the factory examined the tuner preset function before shipment. This is not a malfunction. You can preset the stations you want into memory by following the presetting method.

- There is a time limit in doing the following steps. If the setting is canceled before you finish, start from step 2 again.

On the remote control ONLY:

1 Tune in a station you want to preset.

- See “Tuning in a Station” to the left column.

2 Press SET.

The preset number starts flashing as follows:

- When you select an FM station in step 1

FM-P 1

- When you select an AM (MW/LW) station in step 1

AM-P 1

Preset No. 1 always appears at first.

3 Press the number buttons to select a preset number.

Ex. For preset number 5, press 5.

For preset number 15, press +10, then 5.

For preset number 20, press +10, then 10.

For preset number 30, press +10, +10, then 10.

- You can also select the preset number by pressing ►► or ◄◄.

4 Press SET again.

“STORED” appears on the display for a while.

STORED

The tuned station in step 1 is stored in the preset number selected in step 3.

- Storing a new station on a used number erases the previously stored one.



When you unplug the AC power cord or if a power failure occurs

The preset stations will be erased. If this happens, preset the stations again.

Tuning in a Preset Station

On the remote control ONLY:

1 Press FM/AM repeatedly to select “FM” or “AM (MW/LW).”

The unit automatically turns on with the last selected station.

- Each time you press the button, the band alternates between FM and AM (MW/LW.)

2 Press the number buttons to select a preset number.

Ex. For preset number 5, press 5.

For preset number 15, press +10, then 5.

For preset number 20, press +10, then 10.

For preset number 30, press +10, +10, then 10.

To check the clock time while listening to the broadcast

On the remote control ONLY:

Press DISPLAY (not on number buttons.)

- Each time you press the button, the source information and the clock time alternate on the display.

Receiving FM Stations with RDS

RDS (Radio Data System) allows FM stations to send an additional signal along with their regular program signals. For example, the stations send their station names, as well as information about what type of program they broadcast, such as sports or music, etc.

When tuned to an FM station which provides the RDS service, the RDS indication lights on the display.

With the unit, you can receive the following types of RDS signals.

PS (Program Service):

Shows commonly known station names.

PTY (Program Type):

Shows types of broadcast programs.

RT (Radio Text):

Shows text messages the station sends.

Enhanced Other Networks:

Provides the information about the types of the programs sent by other RDS stations.



More about RDS

- Some FM stations do not provide RDS signals.
- RDS services vary among FM RDS stations. For details on RDS services in your area, check with local radio stations.
- RDS may not work correctly if the received station is not transmitting the signals properly or if the signal strength is weak.

Changing the RDS Information

You can see RDS information on the display while listening to an FM station.

On the remote control ONLY:

1 Press and hold RDS CONTROL until you finish the following procedure.

2 Press DISPLAY (on number buttons.)

- Each time you press the button, the display changes as follows:

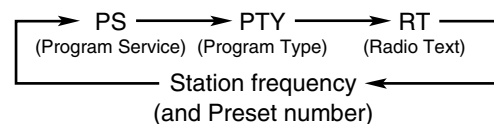

3 Release your finger from RDS CONTROL.



If no PS, PTY, or RT signals are sent by a station “NO PS,” “NO PTY,” or “NO RT” appears on the display.



If the unit takes time to show the RDS information received from a station

“WAIT PS,” “WAIT PTY,” or “WAIT RT” may appear on the display.

Searching for Programs by PTY Codes (PTY Search)

One of the advantages of RDS is that you can locate a particular kind of program by specifying the PTY codes.

- For details on the PTY codes, see “Description of the PTY codes” on page 19.

To search for a program using the PTY codes

- You need to preset FM RDS stations (if not yet done, see page 15), and listen to the FM station.
- There is a time limit in doing the following steps. If the setting is canceled before you finish, start from step 1 again.

On the remote control ONLY:

1 Press and hold RDS CONTROL until you finish the following procedure.

2 Press PTY.
“PTY SELECT” appears on the display.

PTY SELECT

3 Press SELECT + / – to select a PTY code.
The selected PTY code starts flashing on the display.



Ex. “News” is selected.

- For PTY code, see “Description of the PTY codes” on page 19.

4 Press PTY again and release your finger from RDS CONTROL.

While searching, the selected PTY code and “SEARCH” appear alternately on the display.

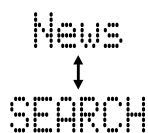

Ex. When “News” is selected as the PTY code.

The unit searches 30 preset FM stations, stops searching when it finds the one you have selected, and tunes in that station.

To continue searching after the first stop

Press PTY (while holding RDS CONTROL) again when the indications on the display are flashing.

If no program is found, “NOT FOUND” appears on the display and the unit returns to the last selected station.

To stop searching any time during the process

Press PTY (while holding RDS CONTROL) when searching.

Switching to a Program Type of Your Choice Temporarily

The Enhanced Other Networks function allows the unit to switch temporarily to a broadcast program of your choice (TA, News, or Info) from a different station.

To activate this function

- This function only works when you are listening to a preset FM RDS stations providing this data.
- The indication lights while receiving a station with your choice data.
- There is a time limit in doing the following steps. If the setting is canceled before you finish, start from step **1** again.

On the remote control ONLY:

1 Press and hold RDS CONTROL until you finish the following procedure.

2 Press TA/NEWS/INFO.
The current indication starts flashing on the display.

3 Press SELECT + / – repeatedly until the indication you want is selected.

- Each time you press SELECT + / –, the indication changes as follows:

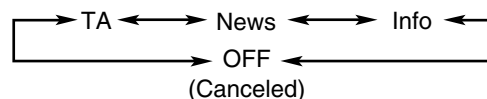

- TA:** Traffic Announcement
- News:** News
- Info:** Programs the purpose of which is to impart advice in the widest sense.
- OFF:** This function is canceled.

4 Press TA/NEWS/INFO again.
The indication disappears.
Now, this function is activated. See “How the Enhanced Other Networks function actually works” on page 18.

5 Release your finger from RDS CONTROL.

To cancel this function, select OFF in step **3** above.

- If you cancel this function while receiving a program selected by this function, the unit returns to the last selected station.

How the Enhanced Other Networks function actually works:

CASE 1

If there is no station broadcasting the program you have selected

The unit continues tuning in the current station.



When a station starts broadcasting the program you have selected, the unit automatically switches to the station. The indication of received PTY code starts flashing.



When the program is over, the unit goes back to the previously tuned station, but the Enhanced Other Networks function still remains activated.

CASE 2

If there is a station broadcasting the program you have selected

The unit tunes in the program. The indication of received PTY code starts flashing.



When the program is over, the unit goes back to the previously tuned station, but the Enhanced Other Networks function still remains activated.

CASE 3

If the FM station you are listening to is broadcasting the program you have selected

The unit continues to receive the station but the indication of received PTY code starts flashing.



When the program is over, the indication of received PTY code stops flashing and remains lit, but the Enhanced Other Networks function still remains activated.

Alarm function

If an “Alarm!” (Emergency) signal is received from a station while listening to the radio, the unit automatically switches to the station broadcasting the “Alarm!” signal, except when you are listening to non-RDS stations (all AM—MW/LW and some FM stations.)

Test function

The TEST signal is used for testing the “Alarm!” signal.

Therefore, it makes the unit work in the same way as the “Alarm!” signal does.

If a TEST signal is received from a station while listening to the radio, the unit automatically switches to the station broadcasting the TEST signal, except when you are listening to non-RDS stations (all AM—MW/LW and some FM stations.)



More about the Enhanced Other Networks function

- This data sent from some stations may not be compatible with this unit. In this case, this function may not work correctly.
- While listening to a program tuned in by this function, the station does not change even if another network station starts broadcasting a program of the same data.
- This function is canceled when you change the source to CD, TAPE, or AUX, while it is temporarily canceled when you change the source to AM (MW/LW.)
- This function is also canceled when you turn off the unit.

Description of the PTY codes:

News:	News.	Finance:	Stock market reports, commerce, trading etc.
Affairs:	Topical program expanding or enlarging upon the news—debate, or analysis.	Children:	Programs targeted at a young audience.
Info:	Program the purpose of which is to impart advice in the widest sense.	Social:	Programs about sociology, history, geography, psychology and society.
Sport:	Program concerned with any aspect of sports.	Religion:	Religious programs.
Educate:	Educational programs.	Phone In:	Involving members of the public expressing their views either by phone or at a public forum.
Drama:	All radio plays and serials.	Travel:	Travel information.
Culture:	Programs concerning any aspect of national or regional culture, including language, theater, etc.	Leisure:	Programs about recreational activities.
Science:	Programs about natural sciences and technology.	Jazz:	Jazz music.
Varied:	Used for mainly speech-based programs such as quizzes, panel games and personality interviews.	Country:	Songs which originate from, or continue the musical tradition of the American Southern States.
Pop M:	Commercial music of current popular appeal.	Nation M:	Current popular music of the nation or region in that country's language.
Rock M:	Rock music.	Oldies:	Music from the so-called "golden age" of popular music.
Easy M:	Current contemporary music considered to be "easy-listening."	Folk M:	Music which has its roots in the musical culture of a particular nation.
Light M:	Instrumental music, and vocal or choral works.	Document:	Program concerning factual matters, presented in an investigative style.
Classics:	Performances of major orchestral works, symphonies, chamber music, etc.	TEST:	Broadcasts for testing emergency broadcast equipment or receiver.
Other M:	Music not fitting into any of the other categories.	Alarm!:	Emergency announcement.
Weather:	Weather reports and forecasts.	Classification of the PTY codes for some FM stations may be different from the above list.	

The buttons emphasized in the illustration below are used and explained in this section (pages 21 to 24.)

Remote control

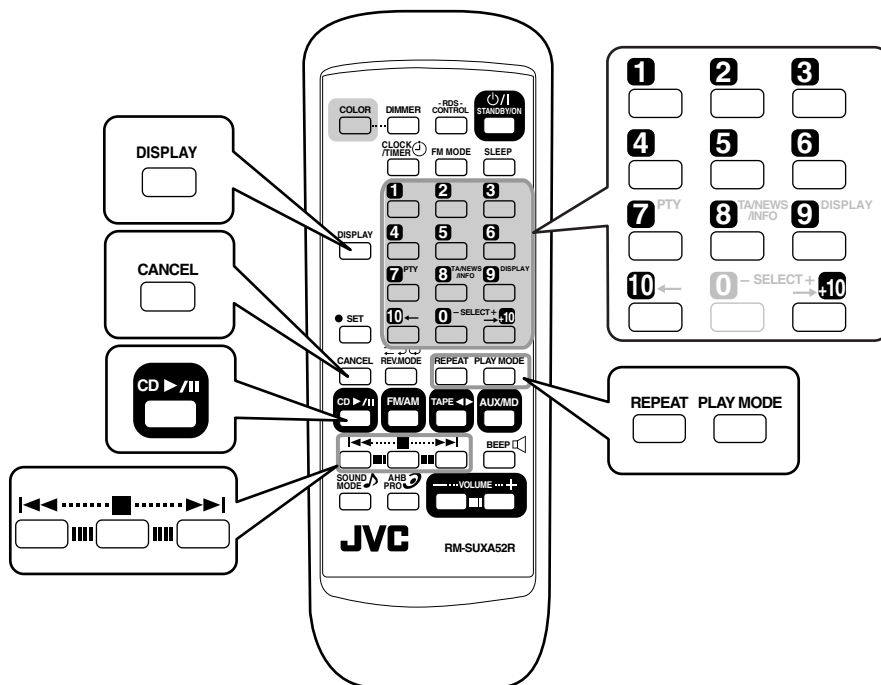

Main unit (Top view)

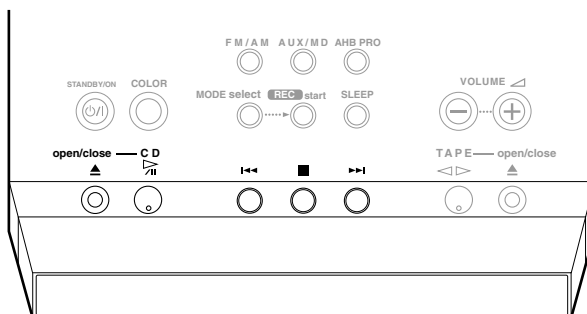

Precautions on CD Playback

This unit has been designed to play back discs bearing the following logos:



CD ReWritable (CD-RW)



CD Recordable (CD-R)



Audio CD

When playing a CD-R or CD-RW

User-edited CD-Rs (CD-Recordable) and CD-RWs (CD-ReWritable) can be played back when they are already “**finalized**.” If you play back an **unfinalized** discs, “UNFINALIZE” appears on the display.

- You can play back your original CD-Rs or CD-RWs recorded in **music CD format ONLY**. (If CD-RWs have been recorded in different format, erase all the data on CD-RWs completely before re-recording on the discs.)



DO NOT play back CD-Rs or CD-RWs including the sound files such as MP3.

- Before playing back CD-Rs or CD-RWs, read their instructions or cautions carefully.
- Some CD-Rs or CD-RWs may not be played back on this unit because of their disc characteristics, damage or stain on them, or if the player’s lens is dirty.

Important notices:

- In general, you will have the best performance by keeping your CDs and the mechanism clean.
 - Store CDs in their cases, and keep them in cabinets or on shelves.
 - Keep the unit’s disc tray closed when not in use.
- Continuous use of irregular shaped discs (heart-shape, octagonal, etc.) can damage the disc rotating mechanism.

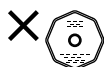
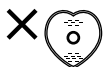

- CD-RWs may require a longer readout time. This is caused by the fact that the reflectance of CD-RWs is lower than for regular CDs.

Playing Back the Entire CD—Normal Play

You can play a CD.

1 Press CD open/close ▲ on the unit.

The unit automatically turns on, the electronic swing panel slides upward, and the disc tray comes out.

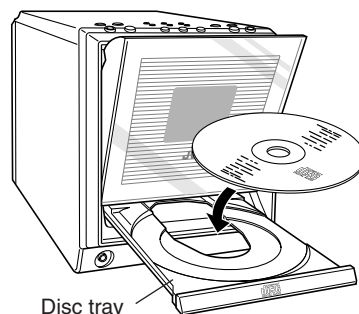

Disc tray

2 Place a CD correctly on the circle of the disc tray with its label side up.

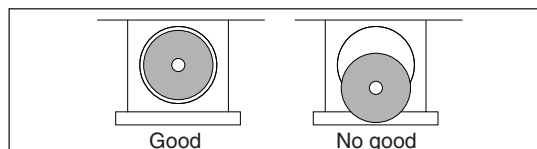

- When using a CD single (8 cm), place it on the inner circle of the disc tray.

3 Press CD ► / II.

The disc tray closes, then the electronic swing panel slides downward automatically.

The CD indicator starts rotating on the display and CD playback starts from the first track.

- If you press CD open/close ▲ again, the disc tray closes, and the electronic swing panel slides downward automatically. CD playback does not start until you press CD ► / II.

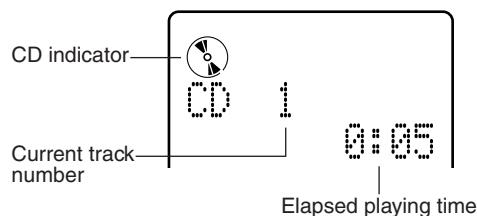

CD playback stops automatically after playing all the tracks on the CD.

To stop during play, press ■.

The following information appears.

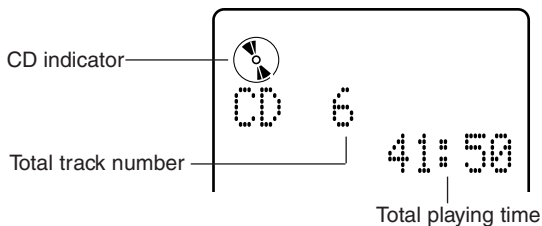

To remove the disc, press CD open/close ▲.

The electronic swing panel slides upward, and the disc tray comes out.

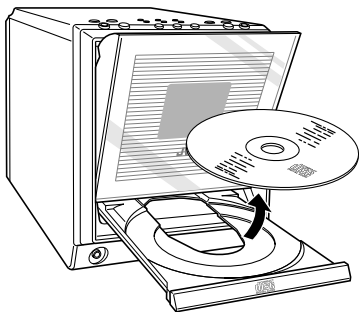

- After removing the CD, press CD open/close ▲ again to close the electronic swing panel.

Basic CD Operations

While playing a CD, you can do the following operations.

To stop playback for a moment

Press **CD ► / II**.

The elapsed playing time starts flashing on the display.

To resume playback, press CD ► / II again.

To locate a particular point in a track during play

Press and hold **►►** or **◄◄**.

- **►►**: Fast-forwards the tracks.
- **◄◄**: Fast-reverses the tracks.

To go to another track

Press **►►** or **◄◄** repeatedly.

- **►►**: Skips to the beginning of the next or succeeding tracks.
- **◄◄**: Goes back to the beginning of the current or previous tracks.

To go to another track directly using the number buttons

On the remote control ONLY:

Pressing the number button(s) allows you to start playing the track number you want.

- Ex.: For track number 5, press 5.
- For track number 15, press +10, then 5.
- For track number 20, press +10, then 10.
- For track number 32, press +10, +10, +10, then 2.

To check the clock time while playing back CD

On the remote control ONLY:

Press **DISPLAY** (not on number buttons.)

- Each time you press the button, the source information and the clock time alternate on the display.

Programming the Playing Order of the Tracks —Program Play

You can arrange the order in which the tracks play before you start playing. You can program up to 32 tracks.

On the remote control ONLY:

- 1** Load a CD.
- 2** Press CD ► / II, then ■.
The source is changed to “CD.”
- 3** Press PLAY MODE repeatedly until “PROGRAM” appears on the display.
 - Each time you press the button, play mode changes as follows:

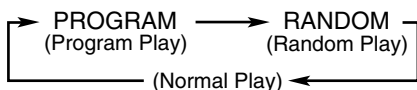

- 4** Press the number buttons to select the tracks.
 - For how to use the number buttons, see “To go to another track directly using the number buttons” on page 22.

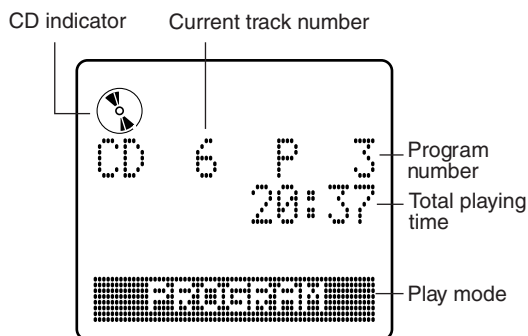

- 5** Press CD ► / II.
The tracks are played in the order you have programmed.
Program Play ends when all the tracks are played once.

To stop during play, press ■.

To exit from Program Play, press PLAY MODE repeatedly so that the unit enters the other play modes (Random Play or Normal Play) before or after play.

To check the program contents

Before playing, you can check the program contents by pressing ◀◀ or ▶▶.

- ◀◀: Shows the programmed tracks in the reverse order.
- ▶▶: Shows tracks in the programmed order.

To modify the program

Before or after playing, you can erase the last programmed track by pressing CANCEL. Each time you press the button, the last programmed track is erased from the program.

To add tracks in the program before you start play, press the number buttons to select track numbers you want to add.

To erase the entire program, press CD open/close ▲ to eject the CD.

- Turning off the unit will also erase the program.



If you try to program a 33rd step
“MEMORY FULL” will appear on the display.



If your entry is ignored
You have tried to program a track number that does not exist on the CD (for example, selecting track 14 on a CD that only has 12 tracks.) Such entries are ignored.



If the total playing time is 100 minutes (one hour and 40 minutes) or more
The total playing time will not be shown. (“-- : --” will appear.)

Playing at Random—Random Play

The tracks of a loaded CD will play at random.

On the remote control ONLY:

- 1 Load a CD.
- 2 Press **CD ▶ / II**, then **■**.
The source is changed to “CD.”
- 3 Press **PLAY MODE** repeatedly until “RANDOM” appears on the display.
 - Each time you press the button, play mode changes as follows:

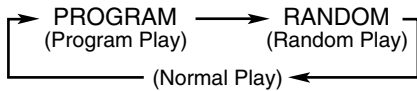

- 4 Press **CD ▶ / II**.
The tracks are played at random.

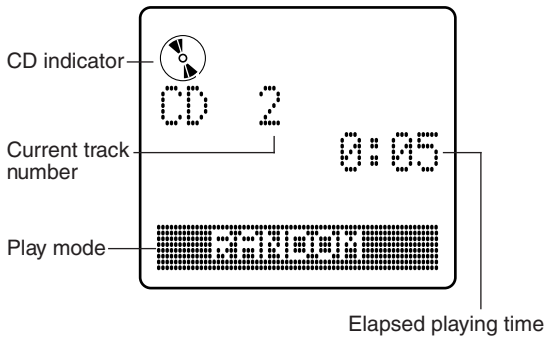

Random Play stops when all the tracks are played once.

To skip the current track, press **▶▶**.

- You cannot go back to the previous tracks by pressing **◀◀**.

To stop during play, press **■**.

To exit from Random Play, press **PLAY MODE** repeatedly so that the unit enters the other play modes (Normal Play or Program Play) before or after play.

Repeating Tracks—Repeat Play

You can repeat all tracks (regardless of play mode), or also a single track as many times as you like.

On the remote control ONLY:

To repeat play, press **REPEAT** before or during play.

- Each time you press the button, Repeat Play changes as follows:

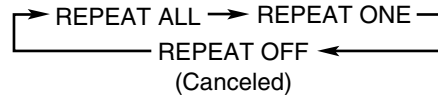

REPEAT ALL : Repeats all the tracks on the CD (in Normal or Random Play), or all the tracks in Program Play.

REPEAT ONE : Repeats only one track.

REPEAT OFF : Cancels Repeat Play.

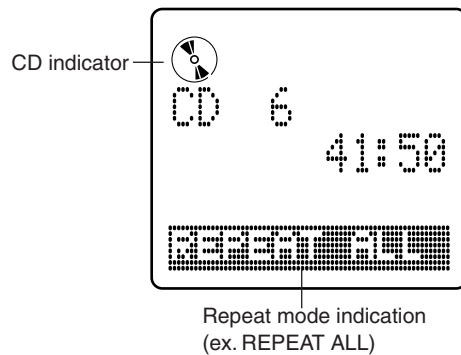

- If play mode is either Program or Random Play, the repeat mode indication appears on the display for a while each time you press **REPEAT**.

To exit from Repeat Play, press **REPEAT** repeatedly until “REPEAT OFF” appears on the display.

Playing Back a Tape

The buttons emphasized in the illustration below are used and explained in this section (page 26.)

Remote control

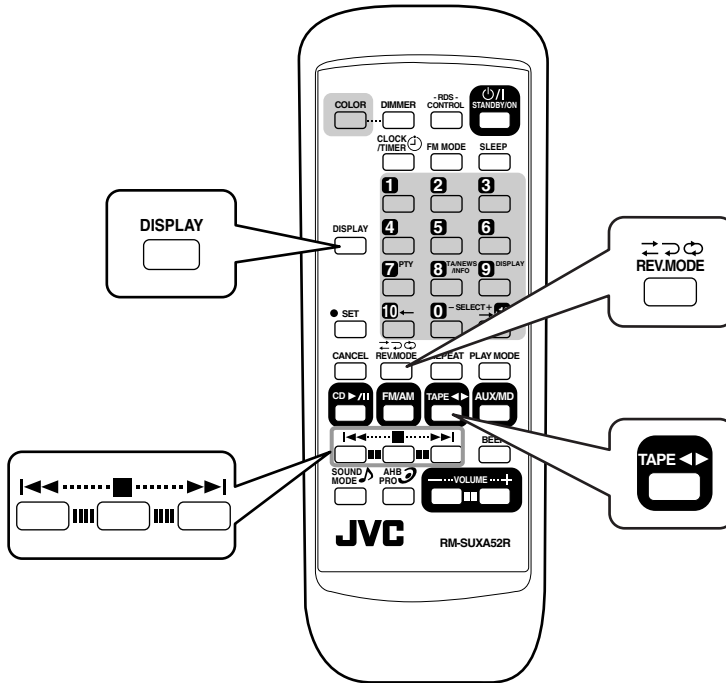

Main unit (Top view)

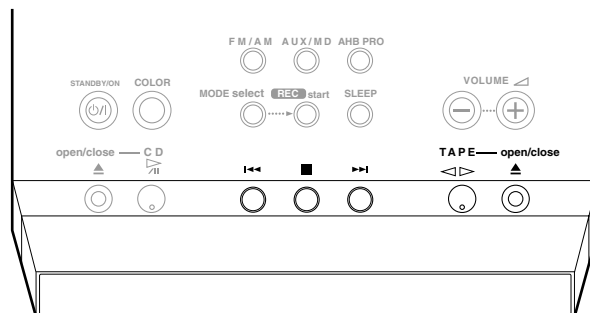

Playing Back a Tape

You can play back type I, II, and IV tapes.

1 Press TAPE open/close ▲ on the unit.

The unit automatically turns on, the electronic swing panel slides downward, and the cassette loading slot appears.

If a cassette is already in the cassette loading slot, it is ejected.

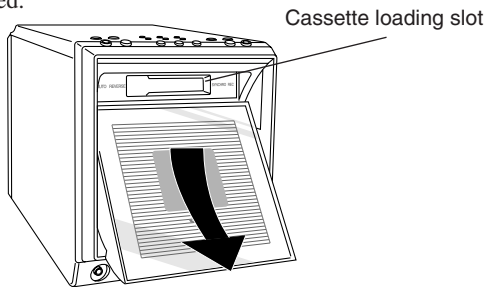

2 Insert a cassette with the exposed part facing left.

The cassette is pulled in, then the electronic swing panel slides upward automatically.

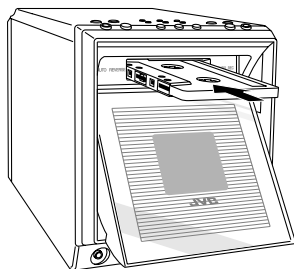

3 Press TAPE ◀▶.

The tape starts playing.

- Each time you press the button, the tape direction changes as follows:

- : Plays the front side.
- : Plays the reverse side.

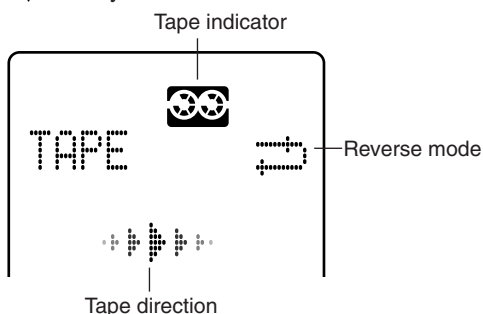

When the tape plays to the end, the cassette deck automatically stops if the reverse mode is set to or . (See “To play both sides—Reverse Mode”.)

To stop during play, press ■.

To fast-wind or rewind the tape, press or .

- When the tape direction is :

: Fast-winds the tape.

: Rewinds the tape.

- When the tape direction is :

: Fast-winds the tape.

: Rewinds the tape.

To eject the cassette, press TAPE open/close ▲.

- After ejecting the cassette, press TAPE open/close ▲ again to close the electronic swing panel.



DO NOT press TAPE open/close ▲ during tape play.

To play both sides—Reverse Mode

You can set the cassette deck to play just one side of a tape, both sides once, or both sides continuously.

- You can set this mode only when a cassette is already in the cassette deck.

On the remote control ONLY:

Press REV. MODE.

- Each time you press the button, the reverse mode changes as follows:

: To only play back one side (front or reverse.)

: To play back the front and reverse sides once.

: To play back both front and reverse sides continuously.

To check the clock time while playing back a tape

On the remote control ONLY:

Press DISPLAY (not on number buttons.)

- Each time you press the button, the source information and the clock time alternate on the display.



The use of the C-120 or thinner tape is not recommended, since characteristic deterioration may occur and this tape easily jams in the pinch rollers and the capstans.

Using External Equipment

The buttons emphasized in the illustration below are used and explained in this section (page 28.)

Remote control

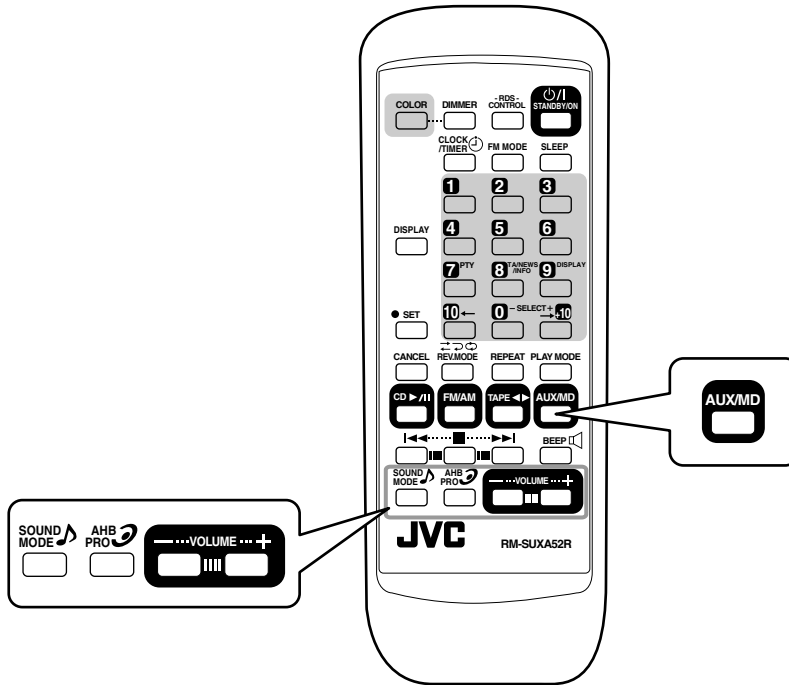

Main unit (Top view)

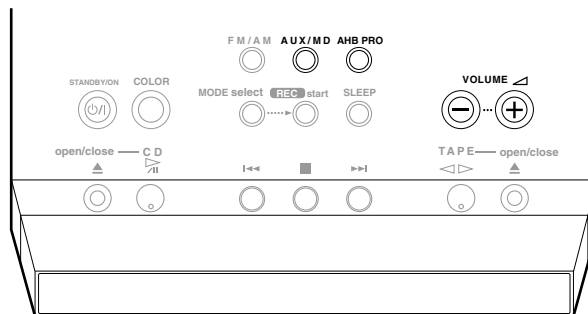

Listening to External Equipment

You can listen to external equipment such as an MD recorder.

- First make sure that the external equipment is properly connected as follows:

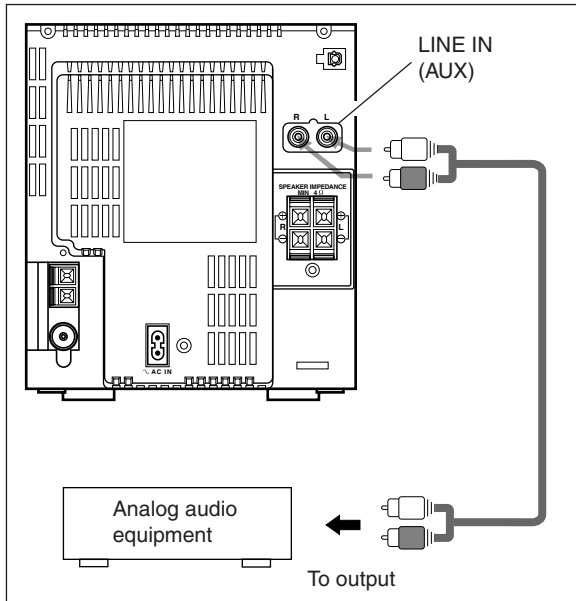

1 Press AUX/MD.

“AUX” appears on the display.

AUX

2 Adjust the volume level to the minimum position.

3 Start playing the external equipment.

- For operation of the external equipment, refer to its manual.

4 Press VOLUME + / - to adjust your desired listening level.

5 Apply sound effects, if you wish.

- Press AHB PRO if you want to reinforce the bass sound.
(See “Reinforcing the Bass sound” on page 12.)
- Press SOUND MODE if you want to control the tone.
(See “Selecting the Sound modes” on page 12.)

Recording from This Unit to External Equipment

You can record from this unit to external equipment connected to the OPTICAL DIGITAL OUT terminal of this unit, such as an MD recorder.

- The recording level is not affected by the VOLUME level and sound effect, either.
- First make sure that the external equipment is properly connected as follows:

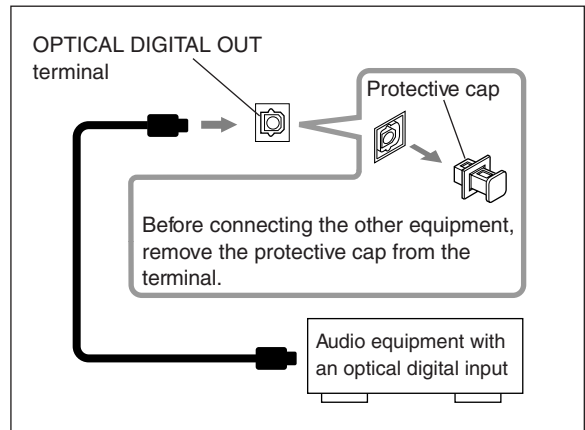

1 Prepare for recording on the external equipment.

2 Start recording on the external equipment.

- For operation of the external equipment, refer to its manual.

3 Play the CD Player of this unit.

- For the CD operation, see page 20 to 24.

To check the clock time while listening to the external equipment

On the remote control ONLY:

Press DISPLAY (not on number buttons.)

- Each time you press the button, “AUX” and the clock time alternate on the display.

Recording on Tapes

The buttons emphasized in the illustration below are used and explained in this section (pages 31 to 32.)
For recording operations, mainly use the buttons on the unit.

Main unit (Top view)

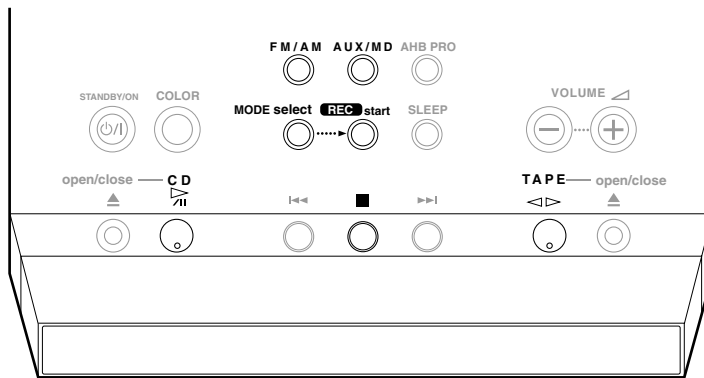

Remote control

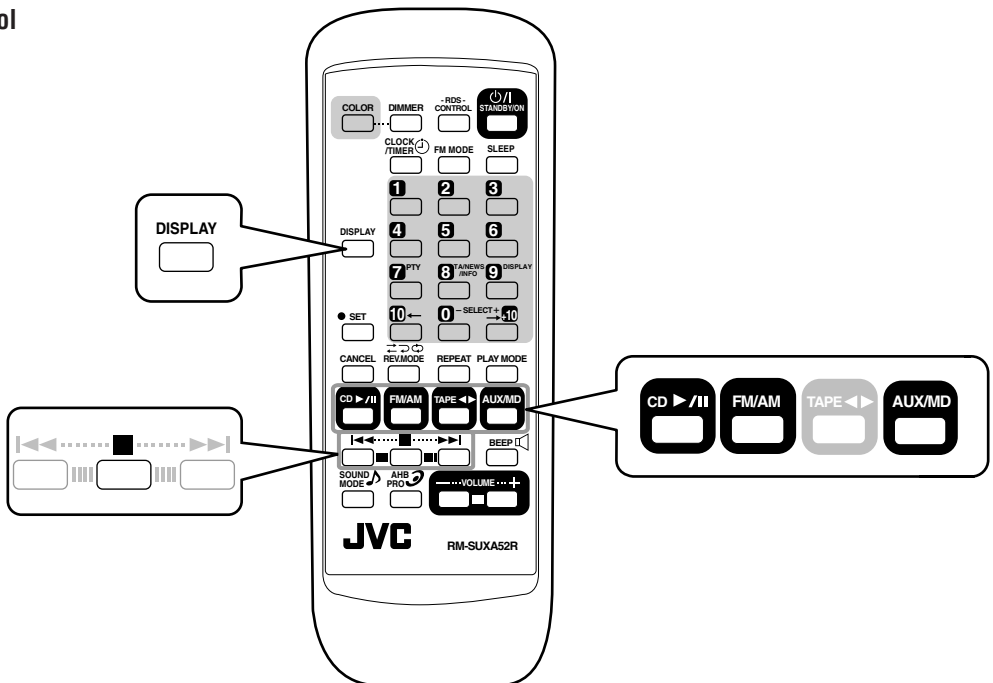

Before You Start Recording

- It should be noted that it may be unlawful to re-record pre-recorded tapes, records, or discs without the consent of the owner of copyright in the sound or video recording, broadcast or cable programme and in any literary, dramatic, musical, or artistic embodied therein.
- The recording level is automatically set correctly, so it is not affected by the VOLUME control. Thus, during recording you can adjust the sound you are actually listening to without affecting the recording level.
- While recording, you can hear sound mode effect and/or the Active Hyper Bass PRO effect through the speakers or headphones. However, the sound is recorded without these effects (see pages 12.)
- While recording, the display lights red.
- If recordings you have made have excessive noise or static, the unit may be too close to a TV. Place the unit away from the TV.
- You can use type I tape for recording.

To protect your recordings

Cassettes have two small tabs on the back to protect unexpected erasure or recording.

To protect your recording, remove these tabs.

To re-record on a protected tape, cover the holes with adhesive tape.

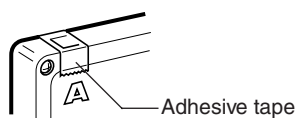

The use of the C-120 or thinner tape is not recommended, since characteristic deterioration may occur and this tape easily jams in the pinch rollers and the capstans.

To keep the best recording and playback sound quality

You need to clean the heads.

- Clean the heads after every 10 hours of use with a wet-type head cleaning tape (available at electronic and audio shops.)

When the head becomes dirty, the following symptoms will occur:

- Sound quality is reduced.
- Sound level decreases.
- Sound drops out.
- Do not play dirty or dusty tapes.
- Do not touch the highly-polished head with any metallic or magnetic tools.

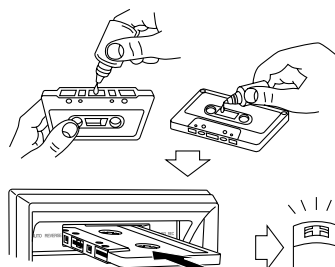

To demagnetize the head

Turn off the unit, and use a head demagnetizer (available at electronic and audio shops.)





At the start and end of cassette tapes

There is leader tape which cannot be recorded onto. Thus, when recording CDs or radio broadcasts, wind the leader tape first to ensure that the recording will be made without any music part lost.

What's a Recording Mode and Reverse Mode ?

You have two methods (MODE 1/2 and 2/2) to record from some sources onto a tape.

Recording mode	Reverse mode
MODE 1/2	
MODE 2/2	

 : To record the front and reverse sides once.

 : To only record one side (front or reverse.)

In the following procedure, MODE 1/2 () is selected as a recording method.

Recording FM/AM (MW/LW) Broadcasts

You can record from an FM or AM (MW/LW) broadcast onto a tape.

On the unit ONLY:

1 Insert a recordable cassette into the cassette loading slot.

- Press TAPE <▷> to adjust the tape direction to “” then ■.

2 Tune in a station you want.

- For more detailed operations, see pages 15 and 16.

3 Press MODE select to select a recording mode.

- Each time you press the button, recording mode changes as follows:

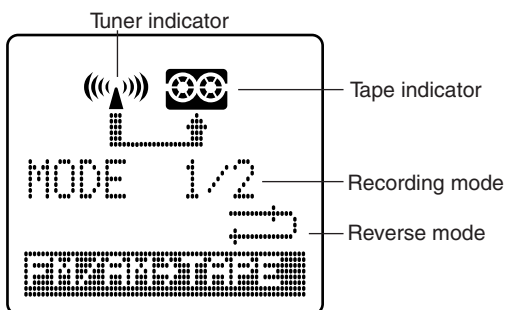
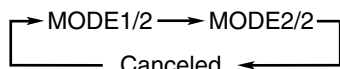

Ex. When selecting MODE 1/2

4 Press REC start.

- The recording starts.

To stop recording, press ■.

To check the clock time while recording from the broadcast onto a tape

On the remote control ONLY:

Press DISPLAY (not on number buttons.)

- Each time you press the button, the recording information and the clock time alternate on the display.

Recording CD—CD Synchronized Recording

You can record from a CD onto a tape.

Using these synchronized recording methods, you can start and stop CD play and tape recording at the same time.

On the unit ONLY:

1 Insert a recordable cassette into the cassette loading slot.

- Press TAPE <▷> to adjust the tape direction to “” then ■.

2 Prepare a CD.

- After loading the CD, press CD ▷ / II, then ■ before going to the next step.
- You can make a program (see page 23) or select Random Play (see page 24) if you want.

3 Press MODE select to select a recording mode.

- Each time you press the button, recording mode changes as follows:

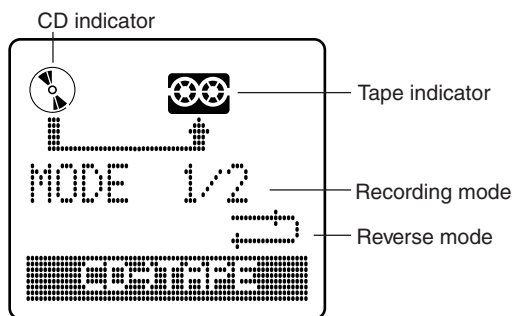
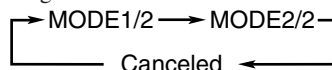

Ex. When selecting MODE 1/2

4 Press REC start.

Both the CD play and the recording start.

- After the recording, both the CD player and the cassette deck stop automatically.

To stop recording, press ■.

CD play stops first, then after 4 seconds, the recording stops.

To record a single track during play or pause

While playing back you want to record, perform steps **3** and **4**.

The playback of the track is stopped, and then starts from the beginning again. This time, the cassette deck starts recording the track.

- After the track is recorded, both the CD player and the cassette deck stop automatically.

To check the clock time while recording from the CD onto a tape

On the remote control ONLY:

Press **DISPLAY** (not on number buttons.)

- Each time you press the button, the recording information and the clock time alternate on the display.

Recording External Equipment

You can record from external equipment onto a tape. The external equipment needs to be connected to LINE IN (AUX) terminal of this unit (for how to connect, see page 9.)

On the unit ONLY:

1 Insert a recordable cassette into the cassette loading slot.

- Press **TAPE** <▷> to adjust the tape direction to “▶▶” then ■.

2 Press **AUX/MD**.

- The source is changed to “AUX.”

3 Press **MODE** select to select a recording mode.

- Each time you press the button, recording mode changes as follows:

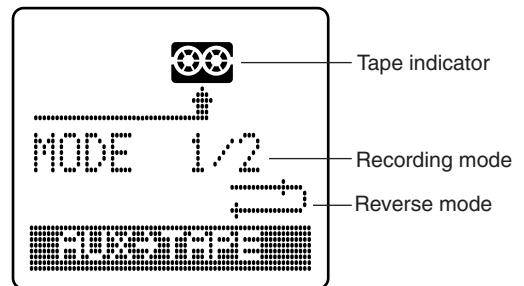
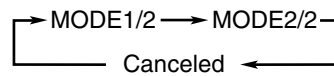

Ex. When selecting MODE 1/2

4 Press **REC** start.

- The recording starts.

5 Start playback on the external equipment.

To stop recording, press ■.

To check the clock time while recording from the external equipment onto a tape

On the remote control ONLY:

Press **DISPLAY** (not on number buttons.)

- Each time you press the button, the recording information and the clock time alternate on the display.

Using the Timers

The buttons emphasized in the illustration below are used and explained in this section (pages 34 to 37.)

Remote control

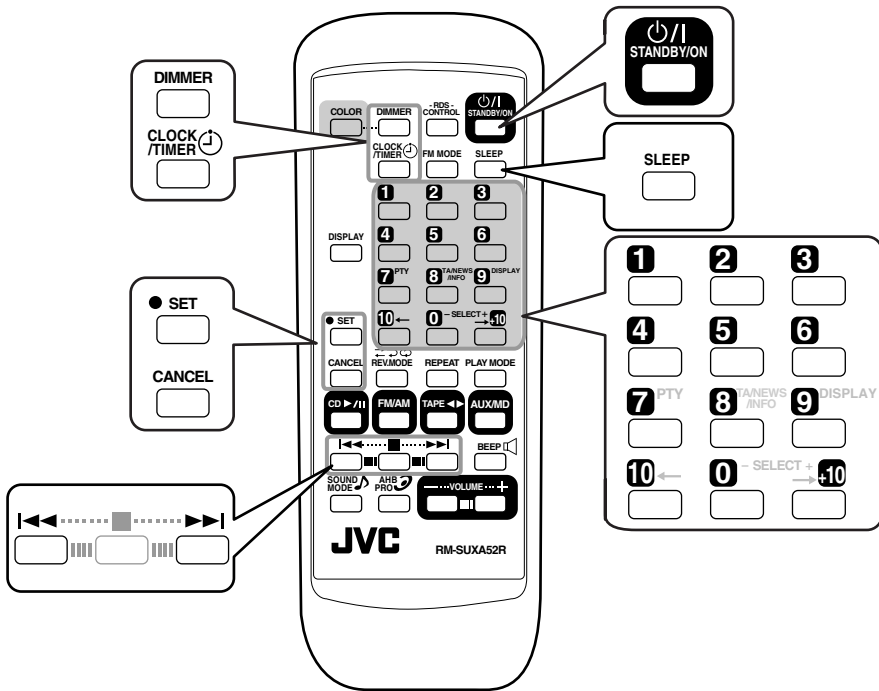

Main unit (Top view)

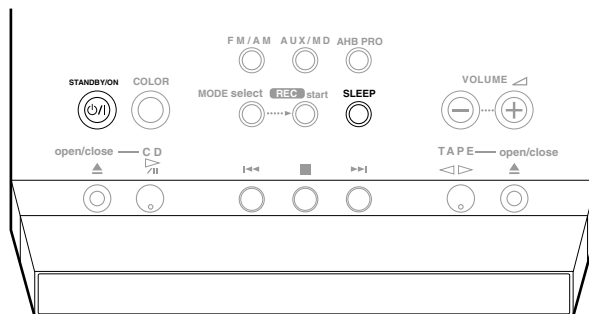

There are three timers available—Recording Timer, Daily Timer, and Sleep Timer.

You need to set the built-in clock to use these timers.

Setting the Clock

You can set the clock whether the unit is turned on or off (on standby.)

On the remote control ONLY:

- 1 Press **CLOCK/TIMER** repeatedly until “**TIME ADJUST**” appears on the display.
The hour digit starts flashing on the display.



- 2 Press **▶▶** or **◀◀** repeatedly to adjust the hour.
 - When you press and hold the button, the hour digit changes continuously.

- 3 Press **SET** to set the hour.
The minute digit starts flashing on the display.

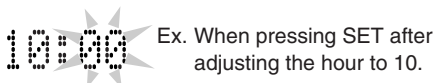

- If you want to correct the hour again, press **CANCEL**.
The hour digit starts flashing again.
- 4 Press **▶▶** or **◀◀** repeatedly to adjust the minute.
 - When you press and hold the button, the minute digit changes continuously.

- 5 Press **SET** to finish setting the clock.
The built-in clock starts.

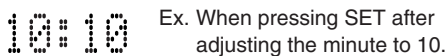

To adjust the clock again

Press **CLOCK/TIMER** repeatedly in step 1 until “**TIME ADJUST**” appears on the display, then perform steps 2 to 5 above.



To check the clock time by sound while the unit is turned off (on standby)

Press **DIMMER** while the key-touch tone is set to on. The clock time will be indicated by sound.



When you unplug the AC power cord or if a power failure occurs

The clock setting will be reset to “0:00.” If this happens, you need to set the clock again.

Using Recording Timer

With Recording Timer, you can make an unattended recording.

- You can set Recording Timer whether the unit is turned on or off (on standby.)
- To correct a misentry any time during the setting process, press **CANCEL**.

How Recording Timer actually works

The unit automatically turns on, and starts recording on a tape when the timer-on time comes. (While Recording Timer is working, the REC indicator keeps flashing.) Then, when the timer-off time comes, the recording stops and the unit automatically turns off (on standby.)

Recording Timer works only once, but the timer settings remain stored in memory unless you reset them or unplug the AC power cord.

On the remote control ONLY:

- 1 Press **CLOCK/TIMER** repeatedly until “**REC TIMER**” appears on the display.

The timer (⌚) indicator lights, and the REC indicator starts flashing on the display.

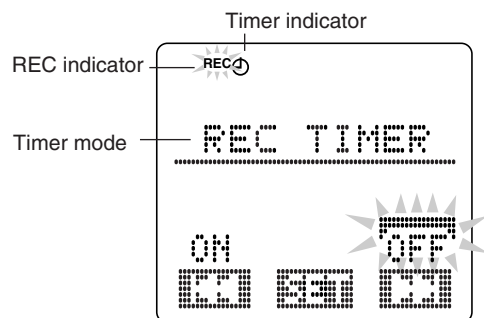

- Each time you press the button, the timer mode changes as follows:

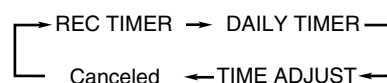

2 Press **◀◀** to select “ON,” then press SET.

3 Select the source to record.

1) Press **▶▶** or **◀◀** repeatedly to select the source.

- Each time you press the buttons, the source changes as follows:

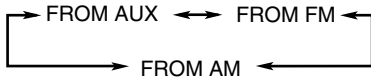

2) Press SET.

- When you have selected “FROM FM” or “FROM AM,” select a preset number by pressing **▶▶** or **◀◀** (for how to preset stations, see page 15.)
- When you have selected “FROM AUX,” the external equipment also needs to have the timer function.

3) Press SET again.

4 Select the reverse mode either **↔** or **↔** by pressing **▶▶** or **◀◀**, then press SET.

- For reverse mode, see page 31.

5 Set the timer-on and timer-off time.

1) Press **▶▶** or **◀◀** repeatedly to select the hour of the timer-on time, then press SET.

The minute digit of timer-on time starts flashing on the display.

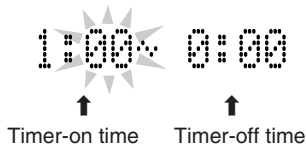

2) Press **▶▶** or **◀◀** repeatedly to select the minute of the timer-on time, then press SET.

The hour digit of timer-off time starts flashing on the display.

3) Press **▶▶** or **◀◀** repeatedly to select the hour of the timer-off time, then press SET.

The minute digit of timer-off time starts flashing on the display.

4) Press **▶▶** or **◀◀** repeatedly to select the minute of the timer-off time, then press SET.

- The setting you have done are shown on the display in sequence.
- The REC indicator stops flashing and remains lit.

6 Press **⏻** STANDBY/ON to turn off the unit (on standby) if necessary.

- No sounds come out while timer recording is performed.

To turn off the Recording Timer after its setting is done,

1 Press CLOCK/TIMER repeatedly until “REC TIMER” appears on the display.

2 Press **▶▶** to select “OFF,” then press SET.

The timer (⌚) and REC indicators go off from the display.

To turn on the Recording Timer again, press **◀◀** to select “ON,” then press SET.

The timer (⌚) and REC indicators light on the display.

The settings you have done are shown on the display for your confirmation.



notes If you stop recording during Recording Timer

The recording is canceled, but when the timer-off time comes, the unit turns off.



notes When you unplug the AC power cord or if a power failure occurs

The timer setting, the tuner preset stations and other settings will be erased.

Using Daily Timer

With Daily Timer, you can wake up to your favorite music or radio program.

- You can set Daily Timer whether the unit is turned on or off (on standby.)
- To correct a misentry any time during the setting process, press CANCEL.

How Daily Timer actually works

The unit automatically turns on, and starts playing the specified source when the timer-on time comes. (While Daily Timer is working, the DAILY indicator keeps flashing.) Then, when the timer-off time comes, the unit automatically turns off (on standby.)

Daily Timer works every day, and the timer settings remain stored in memory unless you reset them or unplug the AC power cord.

On the remote control ONLY:**1** Press **CLOCK/TIMER** repeatedly until **“DAILY TIMER”** appears on the display.

The timer (⌚) indicator lights, and the DAILY indicator starts flashing on the display.

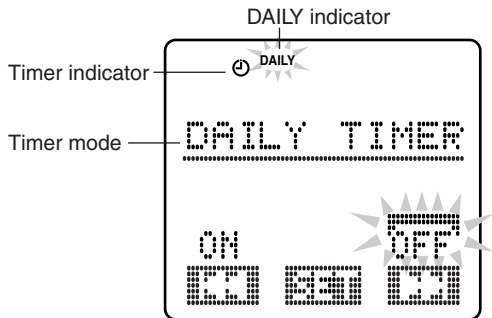

- Each time you press the button, the timer mode changes as follows:

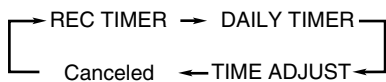
**2** Press **◀◀** to select **“ON,”** then press **SET**.**3** Select the source to play.

- 1) Press **▶▶** or **◀◀** repeatedly to select the source.
 - Each time you press the buttons, the source changes as follows:

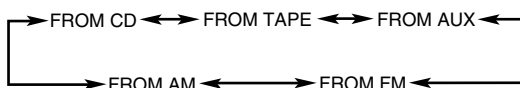
2) Press **SET**.

- **When you have selected “FROM FM” or “FROM AM,”** select a preset number by pressing **▶▶** or **◀◀** (for how to preset stations, see page 15.)
- **When you have selected “FROM AUX,”** the external equipment also needs to have the timer function.

3) Press **SET** again.**4** Set the timer-on and timer-off time.

- 1) Press **▶▶** or **◀◀** repeatedly to select the hour of the timer-on time, then press **SET**.

The minute digit of timer-on time starts flashing on the display.



↑ Timer-on time ↑ Timer-off time

- 2) Press **▶▶** or **◀◀** repeatedly to select the minute of the timer-on time, then press **SET**.

The hour digit of timer-off time starts flashing on the display.

- 3) Press **▶▶** or **◀◀** repeatedly to select the hour of the timer-off time, then press **SET**.

The minute digit of timer-off time starts flashing on the display.

- 4) Press **▶▶** or **◀◀** repeatedly to select the minute of the timer-off time, then press **SET**.

5 Adjust the volume level.

- 1) Press **▶▶** or **◀◀** repeatedly to adjust the volume level.

- You can adjust the volume level within the range of 0 (silent) to 40 (maximum.)
- When you select **“VOLUME – –,”** the volume is set to the current volume level.

- 2) Press **SET**.

- The settings you have done are shown on the display in sequence.
- The DAILY indicator stop flashing and remains lit on the display.

6 Press **⏻/|** **STANDBY/ON** to turn off the unit (on standby.)

To turn off the Daily Timer after its setting is done,

- 1) Press **CLOCK/TIMER** repeatedly until **“DAILY TIMER”** appears on the display.

- 2) Press **▶▶** to select **“OFF,”** then press **SET**.

The timer (⌚) and DAILY indicators go off from the display.

To turn on the Daily Timer again, press **◀◀** to select **“ON,”** then press **SET**.

The timer (⌚) and DAILY indicators light on the display.

The settings you have done are shown on the display for your confirmation.



If the unit is kept turned on until the timer-on time comes

Daily Timer does not work at all.



Daily Timer will be canceled and the unit will not turn off automatically in the following:

- When you change the source.



When you unplug the AC power cord or if a power failure occurs

The timer setting, the tuner preset stations and other settings will be erased.

Using Sleep Timer

With Sleep Timer, you can fall asleep to your favorite music.

- You can set Sleep Timer while the unit is turned on.

How Sleep Timer actually works

The unit automatically turns off after the specified time length passes.

- 1 Press SLEEP repeatedly until the time length you want appears on the display.**

The timer (⌚) indicator starts flashing and “SLEEP 10” appears on the display.

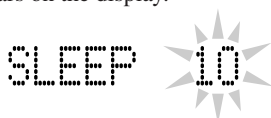

- Each time you press the button, the time length changes as follows:

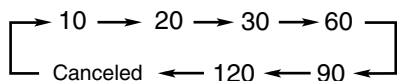

- 2 Press SET or wait for about 5 seconds.**

The display dims.

“SLEEP” appears on the display.

To check the remaining time until the shut-off time, press SLEEP once. The remaining time until the shut-off time appears for about 5 seconds.

To change the shut-off time, press SLEEP repeatedly until the time length you want appears.

To cancel the setting, press SLEEP repeatedly until “SLEEP” disappears from the display.



Sleep Timer will be canceled in the following:

- When you turn off the unit.
- When you operate other timer settings.
- When you adjust the clock.



If “CLOCK ADJUST” appears on the display

You need to set the built-in clock (see page 34.)

To sleep with the Sleep Timer and wake up with the Daily Timer

The unit turns off when the shut-off time comes (set by the Sleep Timer), and turns on when the timer-on time comes (set by the Daily Timer.)

- 1 Set the Daily Timer as explained on pages 35 and 36.**
- 2 Start playing back any source you want to listen to before sleep.**
- 3 Set the Sleep Timer.**

Timer Priority

Since each timer can be set separately, you may wonder what happens if the setting for these timers overlaps. Here are the priorities for each timer.

- **A timer with the later timer-on time has priority.**
If Recording Timer is set to come on while Daily Timer is operating, Daily Timer is canceled.

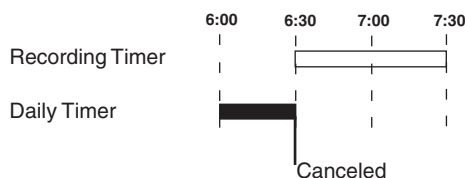

If Recording Timer is set to come on while Sleep Timer is operating, Sleep Timer will not shut off the power even if the shut-off time comes.

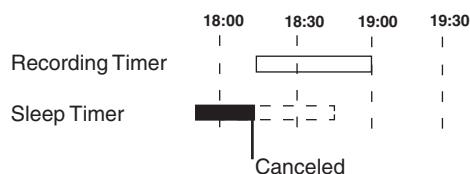

Maintenance

To get the best performance of the unit, keep your discs, tapes, and mechanism clean.

General Notes

In general, you will have the best performance by keeping your discs and the mechanism clean.

- Store discs in their cases, and keep them in cabinets or on shelves.
- Keep the electronic swing panel closed when not in use.

Cleaning the unit

• Stains on the unit

Should be wiped off with a soft cloth. If the unit is heavily stained, wipe it with a cloth soaked in water-diluted neutral detergent and wrung well, then wipe clean with a dry cloth.

- **Avoid the following since they may cause damage to the unit.**
 - DO NOT wipe it with a hard cloth.
 - DO NOT wipe it strong.
 - DO NOT wipe it with thinner or benzine.
 - DO NOT apply any volatile substance such as insecticides to it.
 - DO NOT allow any rubber or plastic to remain in contact with it for a long time.

Handling discs



- Remove the disc from its case by holding it at the edge while pressing the center hole lightly.
- Do not touch the shiny surface of the disc, or bend the disc.
- Put the disc back in its case after use to prevent warping.

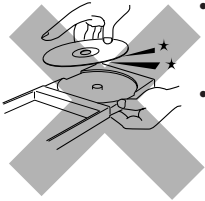

- Be careful not to scratch the surface of the disc when placing it back in its case.
- Avoid exposure to direct sunlight, temperature extremes and moisture.



To clean the disc

Wipe the disc with a soft cloth in a straight line from center to edge.

Handling cassette tapes

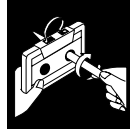

- If the tape is loose in its cassette, take up the slack by inserting a pencil in one of the reels and rotating.
- If the tape is loose, it may get stretched, cut, or caught in the cassette.



- Be careful not to touch the tape surface.



- Avoid the following places to store the tape:
 - In dusty places
 - In direct sunlight or heat
 - In moist areas
 - On a TV or speaker
 - Near a magnet



DO NOT use any solvent—such as conventional record cleaner, spray, thinner, or benzine—to clean the disc.

Specifications

UX-A52R (CA-UXA52R and SP-UXA52)

Amplifier

Output Power (IEC 268-3/DIN):
40 W (20 W + 20 W) at 4 Ω (10 % THD)
Audio input sensitivity/Impedance (at 1 kHz)
LINE IN (AUX): 500 mV/47 k Ω
Digital output – OPTICAL DIGITAL OUT
Signal wave length: 660 nm
Output level: -21 dBm to -15 dBm
Speaker Terminals: 4 Ω — 16 Ω

Tuner

FM tuning range:
87.50 MHz — 108.00 MHz
AM (MW/LW) tuning range:
MW: 522 kHz — 1 629 kHz
LW: 144 kHz — 288 kHz

CD player

CD capacity: 1 CD
Dynamic range: 85 dB
Signal-to-noise ratio: 90 dB
Wow and flutter: Immeasurable

Cassette deck

Frequency response
Normal (type I): 60 Hz — 14 000 Hz
Wow and flutter
0.15 % (WRMS)

General

Power requirement: AC 230 V \sim , 50 Hz
Power consumption: 45 W (at operation)
1.2 W (on standby)
Dimensions (approx.):
163 mm x 200 mm x 329 mm (W/H/D)
Mass (approx.): 4.3 kg

Speaker Section

Speakers: Woofer 10 cm, Tweeter 4 cm
Impedance: 4 Ω
Dimensions (approx.):
140 mm x 200 mm x 249 mm (W/H/D)
Mass (approx.): 2.0 kg

Supplied accessories

See page 6.

Design and specifications are subject to change without notice.



JVC
VICTOR COMPANY OF JAPAN, LIMITED